

**JUKI**

2-Needle, Unison Feed  
Lockstitch Industrial Sewing Machine

**LG-158**

1-Needle, Unison Feed  
Lockstitch Industrial Sewing Machine

**LG-158-1**

**INSTRUCTION MANUAL**

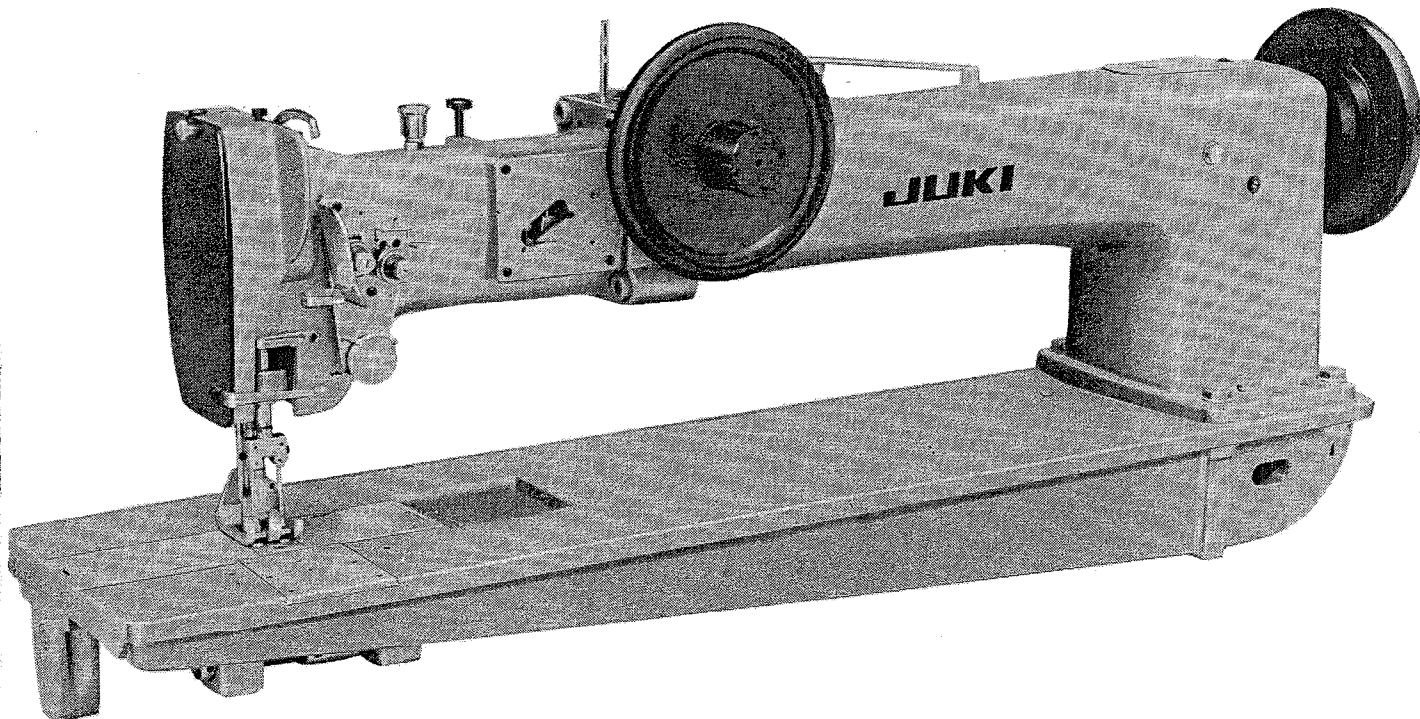

**No.00**

**BE1580S0B0A**

## BY WAY OF INTRODUCTION . . . . .

JUKI Model LG-158 (LG-158-1) is a two-needle (single needle), unison feed, lockstitch industrial sewing machine with a reverse feed mechanism.

Two sewing hooks(one) of rotary vertical axis are used which are driven by timing belt.

Presser lifting amount is 16mm(5/8"), maximum stitch length is 10mm(25/64") and a unison feed mechanism is adopted so that the needle feed and the unison feed completely synchronize each other to prevent the upper and lower cloth from slipping.

Also, reverse sewing can be performed by means of the pedal.

For safe maintenance of the machine, a special safety device is incorporated, so this machine is best suited for sewing extremely heavy weight materials, and heavy weight materials such as tent, seat, leather goods, etc.

## SPECIFICATIONS

	<u>LG-158</u>	<u>LG-158-1</u>
Usage .....	For sewing extremely heavy weight & heavy weight materials	
Sewing speed .....	Up to 1,500 s.p.m.	
Presser lifting amount .....	16mm(5/8")	
Stitch length .....	0~10mm(25/64")	
Needles .....	DD x 1 #25 2 ea.	DD x 1 #25 1 ea.
Lubricating oil .....	New Defrix Oil No. 1	
Motor .....	400W (1/2HP) clutch motor, 4 Pole	
Reverse sewing .....	By treading pedal	
Needle gauge .....	3/4" (Standard)	
(LG-158)	1/4", 5/16", 3/8", 1/2", 1" 1-1/4", 1-1/2", 2", 2-1/2"	
	*The gauge exchanging parts are needle bar (with needle clamp), presser foot, walking foot, throat plate, feed dog and bed slide (left, right). When gauge of over 1-1/4" is to be used, besides the above parts, exchange the following parts also: Hook driving shaft front bushing Hook driving shaft intermediate bushing Needle thread guide (lower)	

## CONTENTS

	Page
CAUTIONS ON OPERATION .....	1
LUBRICATION .....	1
INSTALLING THE NEEDLE .....	2
ON THREADS .....	2
HOW TO PASS THE BOBBIN THREAD .....	2
PASSING THE NEEDLE THREAD .....	3
THREAD TENSION .....	4
Needle thread tension .....	4
Bobbin thread tension .....	4
Thread take-up spring .....	4
HOW TO WIND THE BOBBIN THREAD .....	5
ON THE SAFETY DEVICE .....	5
RELATIONSHIP BETWEEN THE NEEDLE AND THE SEWING HOOK .....	6
1. Timing of needle with the sewing hook .....	6
2. Height of the needle bar .....	6
3. How to match the timing of the sewing hook .....	6
4. Adjusting the clearance between the needle and blade point of sewing hook .....	6
INSTALLING AND DISMANTLING THE SEWING HOOK .....	7
1. Dismantling the sewing hook .....	7
2. How to install the sewing hook .....	7
ADJUSTING THE BOBBIN CASE OPENING LEVER .....	7
HEIGHT OF THE PRESSER FOOT .....	8
INSTALLING POSITION OF THE PRESSER FOOT .....	8
ADJUSTING THE STITCH LENGTH .....	9
ADJUSTING THE HEIGHT OF THE FEED DOG .....	9
ON REVERSE SEWING .....	9
ADJUSTING THE PRESSER FOOT AND THE WALKING FOOT .....	10
ADJUSTING THE LIFTING AMOUNT OF THE PRESSER FOOT AND THE WALKING FOOT .....	10
HOW TO REMOVE THE BOBBIN CASE HOLDER .....	11
EXCHANGING THE TIMING BELT .....	11
TIMING OF MAIN SHAFT AND HOOK SHAFT .....	11
ADJUSTING THE FORE & AFT POSITION OF NEEDLE BAR VIBRATING BASE .....	12
MALFUNCTIONS, CAUSES & CORRECTIVE MEASURES .....	13

## CAUTIONS ON OPERATION

- ① Do not ever start operating the machine without first filling up the oil reservoir and lubricate the machine even for trial running.
- ② The machine should rotate toward the operator, always. Never rotate the machine in the reverse direction.
- ③ The maximum sewing speed of this machine is up to 1,500 s.p.m. But when the machine is to be used for the first time, run the machine at a moderate speed of 1,000 s.p.m. for a while.

## LUBRICATION

### \*Before starting the machine:

1. For lubrication, use JUKI New Defrix Oil No.1 which is in the accessory box.
2. Before operating the machine, lubricate the parts shown by arrows in the figure. To lubricate the face part, loosen the face plate set screw and by placing the face plate on top, lubricate the oil wick and the moving parts.
3. When the machine is to be used continuously, lubricate it at least twice a day.
4. Finally, when the machine is to be used for the first time or when it is used to sew long length material continuously, be sure to lubricate it often.

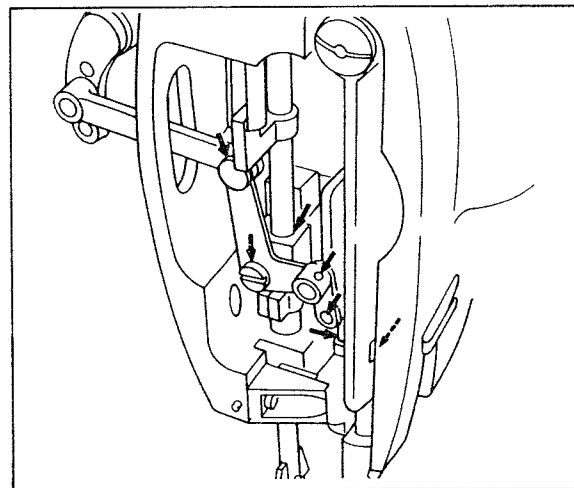
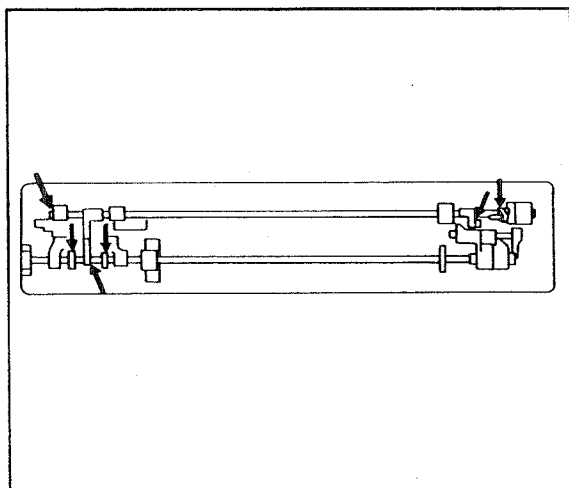
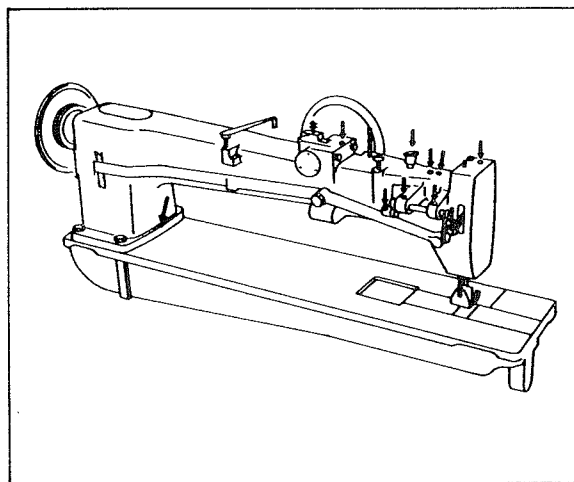
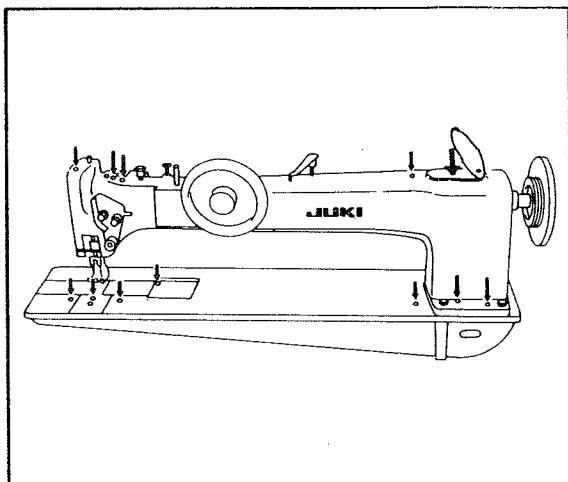

## INSTALLING THE NEEDLE

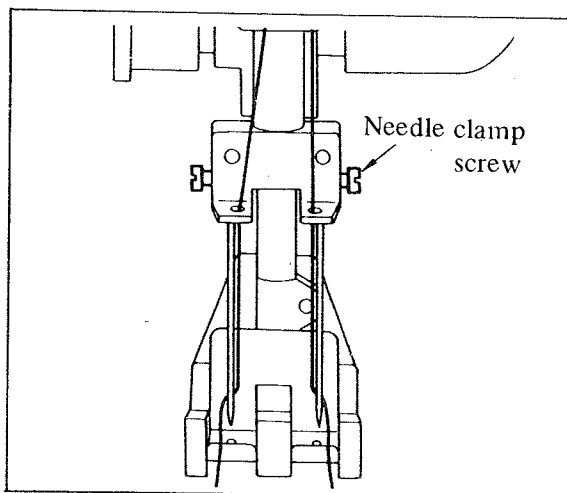

Use DD x 1 needle. There are many types and size numbers of needles but all of them depend upon the thickness of the thread or kinds of sewing material, so be sure to select appropriate type and size number.

Standard is #25.

To install the needle:

1. Raise up the needle bar to its highest position.
2. Long grooves of both right and left needles should be facing inside (both long grooves facing each other) and insert the needles deep into the needle hole as far as they will go in and set them tightly with needle clamp screw.

## ON THREADS

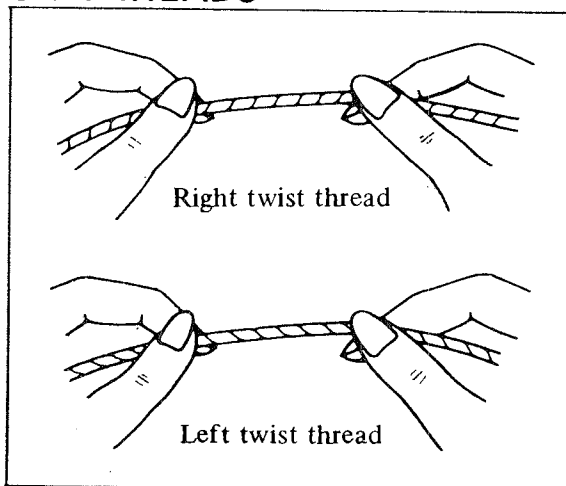

For the needle thread, left-twist thread should be used. For the bobbin thread, either left-twist or right-twist thread can be used.

To verify the twist of thread, hold the thread as shown in the figure and if the thread is twisted toward front by the left hand and is wound tight, it is a right-twist thread. On the contrary, if the thread in the right hand is twisted toward front and is wound tightly, it is left-twist thread.

## HOW TO PASS THE BOBBIN THREAD

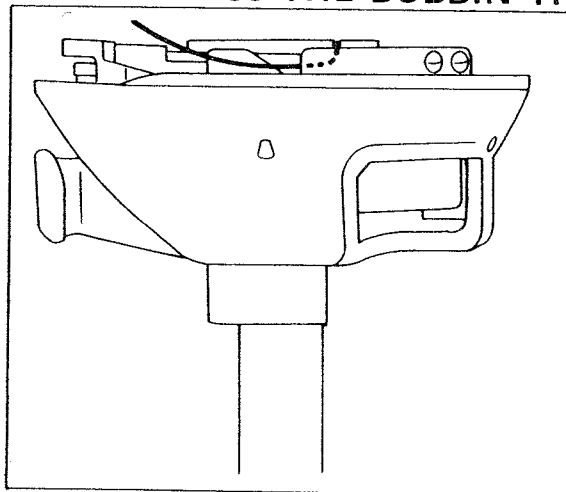

Open the lever of the sewing hook, insert the bobbin and knock down the lever to its original position.

If the bobbin thread is pulled out from the groove of the sewing hook, the thread will pass under the bobbin thread tension spring. Pull out the bobbin thread about 5cm (about 2") on top of the slide plate.

## PASSING THE NEEDLE THREAD

Pass the needle threads in order shown in below.

As you face the machine, left side needle thread should be passed from ① → ⑬ (Left thread tension disc → upper hole of take-up lever → left needle)

The right side needle should be passed, in order, from ① ~ ④ ~ ⑤ ~ ⑧ ~ ⑨ ~ ⑩ ~ ⑪ ~ ⑫ ~ ⑬ ~ ⑭ (right thread tension disc → lower hole of take-up lever → right needle)

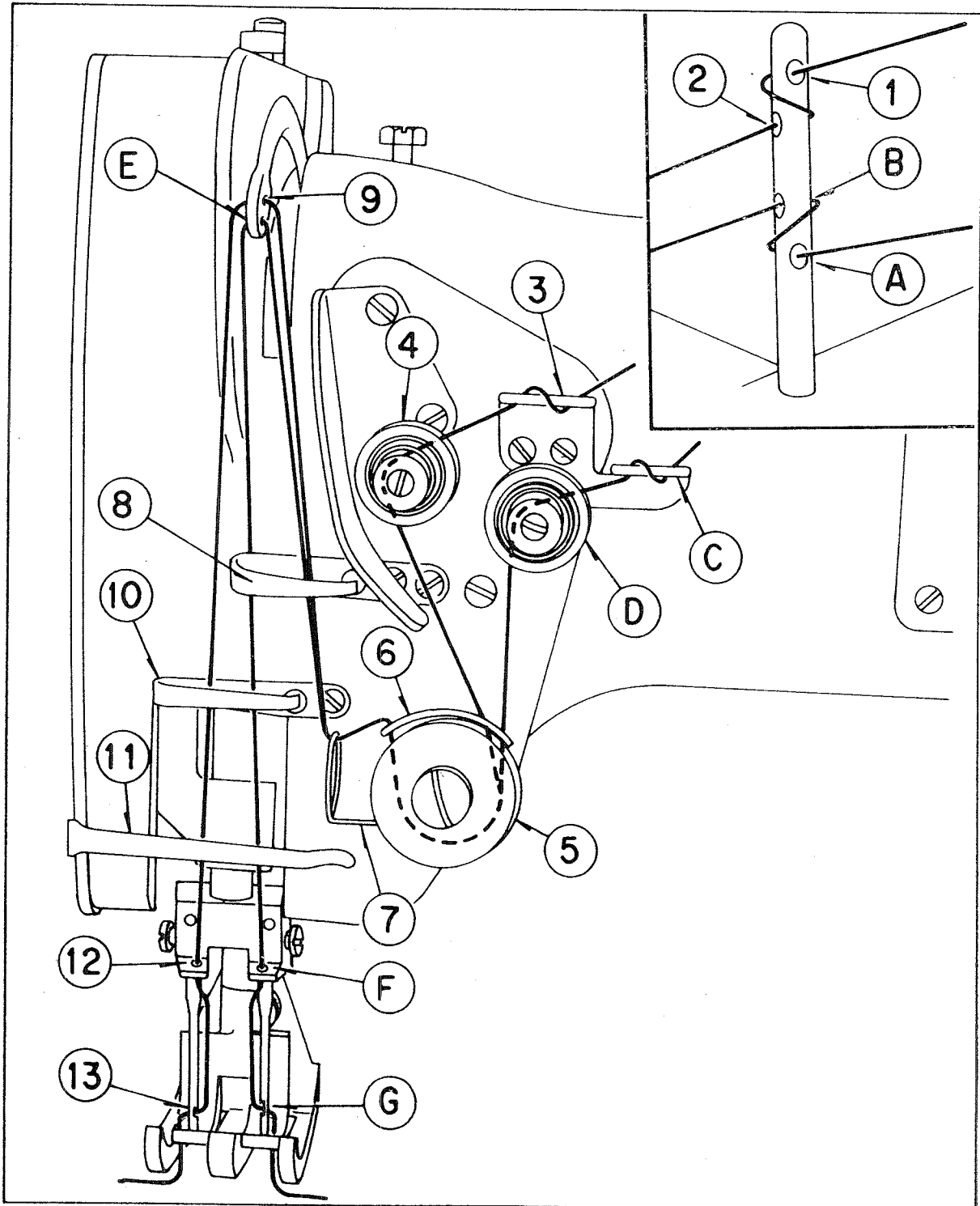

## THREAD TENSION

d

F

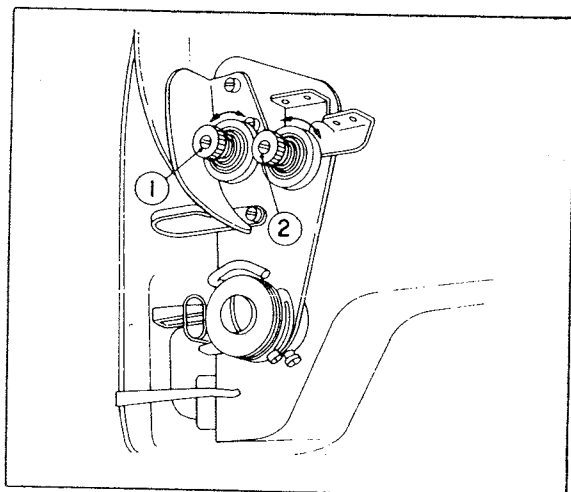

### \*Needle thread tension

The thread tension of the right side needle can be adjusted by the right side thread tension nut ① and the left side needle thread can be adjusted by the left side thread tension nut. Turn the nut to right to make the needle thread tension stronger and to left to make the tension weaker.

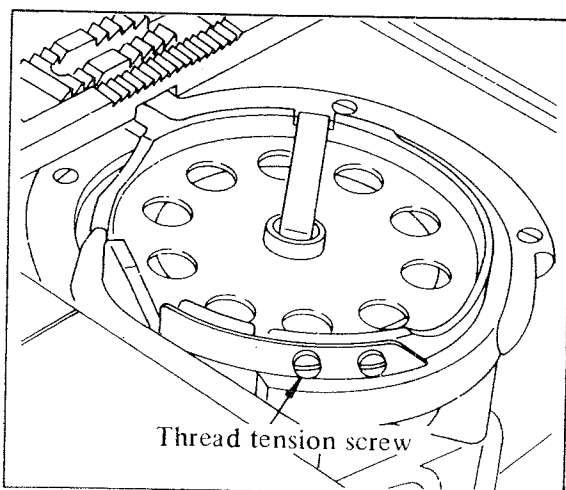

### \*Bobbin thread tension

The thread tension of the bobbin thread can be adjusted by turning the thread tension screw of the bobbin case holder. If the screw is tightened, the tension becomes stronger and if it's loosened, the tension becomes weaker.

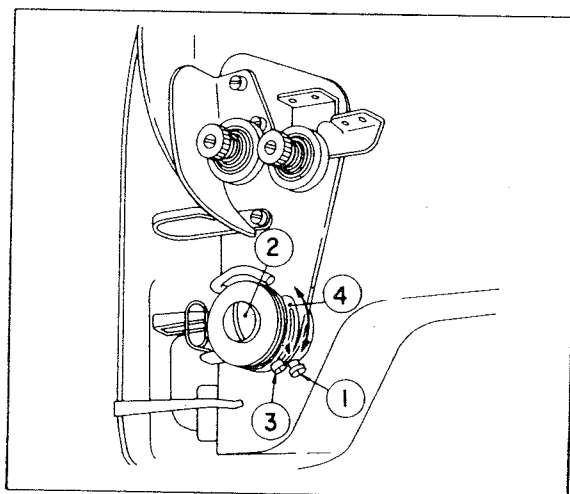

### \*Thread take-up spring

To adjust the strength of the thread take-up spring, loosen the thread take-up spring shaft screw ①, and turn the thread take-up guide shaft ② gently toward left. To weaken the tension, rotate it toward right. After the adjustment, tighten the screw ①. To adjust the stroke of the take-up spring, loosen the stopper set screw ③ and move the stopper ④ to right and left. If the stopper is moved toward right, the stroke gets bigger.

## HOW TO WIND THE BOBBIN THREAD

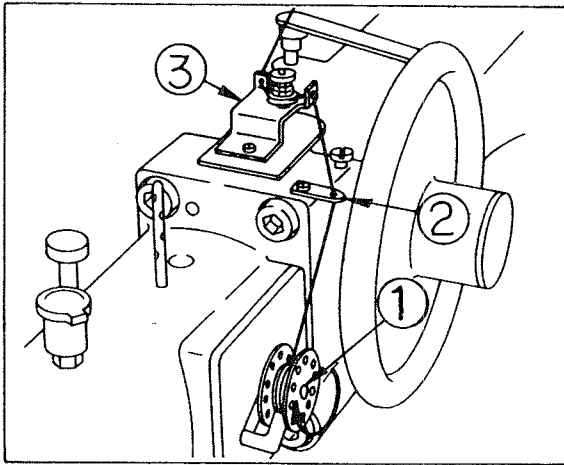

The bobbin thread winder of this machine is built-in to the frame of the machine. To wind the bobbin thread, first insert the bobbin to the bobbin winding shaft ① as far as it will go. Next, pass the thread to bobbin thread guide base ③ and bobbin thread winder guide ②, as shown in the figure, and wind the thread to the bobbin several times from the bottom. Then, push in the bobbin trip latch ④ and rotate the machine. When the fixed amount of thread is wound, the winding will stop automatically.

## ON THE SAFETY DEVICE

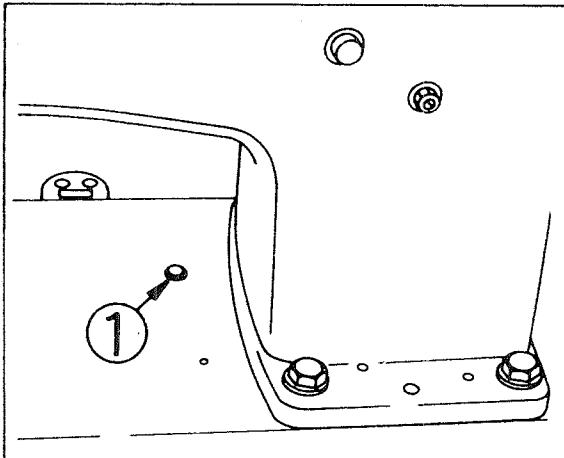

During the running of the machine, sometimes the thread gets caught by the sewing hook, causing an unnecessary exertion to the machine. In such cases, the safety device goes into action automatically to prevent damages to the machine. When the safety device is acting, the feed and the sewing hook do not move even if the hand wheel is rotated. When the safety device is acting, remove the cause of the defect and set the safety device to the original status by the following method:

1. While pushing the push button ①, push the auxiliary hand wheel and rotate strongly toward the left direction.  
Be sure to verify that the safety device is set and then operate the machine.
2. When the safety device jumps into action quickly, remove the timing belt and rotate the adjusting screw ② to right.

Conversely, when the safety device does not go into action and the machine is damaged (needle, sewing hook, etc.), rotate the adjusting screw ② to left. With a slight force, the safety device will spring to action.

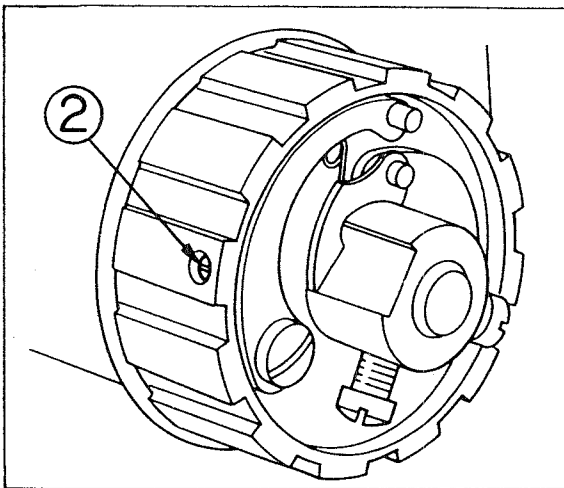



# RELATIONSHIP BETWEEN THE NEEDLE AND THE SEWING HOOK

## 1. Timing of the needle with the sewing hook

First, set the feed amount to "0" and verify that the clearance between the presser bar and the walking bar is 17mm(43/64").

Raise up the presser foot and after matching the feed graduator plate to "0", remove the throat plate.

\*When the needle has risen 3.5mm(9/64") from the lowest point,

\*Match the blade point of the sewing hook with the center of the needle. At this point,

\*The clearance between the needle side surface and the blade point of the sewing hook comes to 0~0.05mm(1/512"),

\*The clearance between the needle side surface and the needle guard of the sewing hook comes to 0~0.05mm(1/512"),

\*The distance between the upper tip of the thread hole of the needle and the tip of the sewing hook blade comes to 3.0mm(1/8").

## 2. Height of the needle bar

First, set the feed graduator to 0mm, and bring the needle bar to its lowest point. At this point, make the distance between the bottom end of the needle clamp to the surface of the throat plate to 21.2mm(53/64") and tighten the needle bar clamping screw.

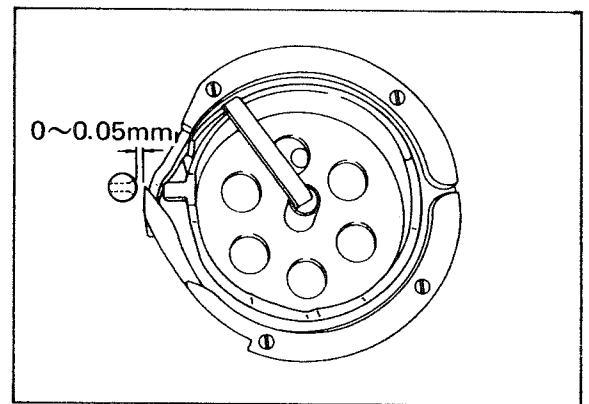
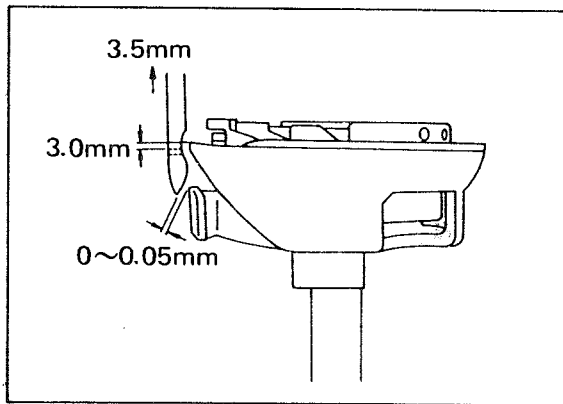

## 3. How to match the timing of sewing hook

Loosen the set screw ① of the large gear of the hook shaft, move the large gear ② to right and left and when the center of the needle and the blade point of the sewing hook are matched together, tighten the set screw ①. At this point, be careful to see that the center gear of the large gear and the center of the hook shaft do not slide each other.

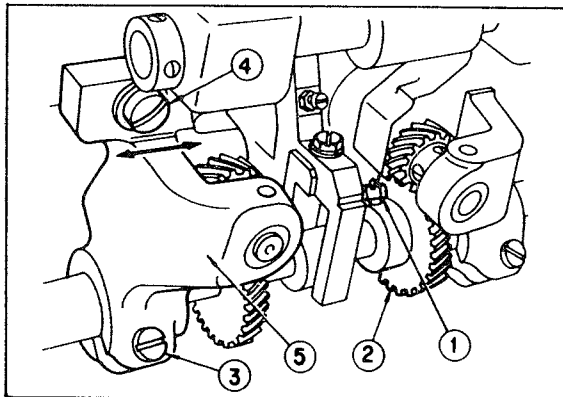

## 4. Adjusting the clearance between the needle and blade point of the sewing hook

Make adjustment as follows:

- 1) Remove the presser foot and the throat plate and tilt the machine.
- 2) Loosen the clamp screw ③ and set screw ④ of the hook driving shaft saddle of the adjusting side.
- 3) Tap the hook driving shaft saddle ⑤ lightly and move it to right and left and by making the clearance between the needle and the blade point of the hook to 0~0.05mm(1/512"), tighten the clamp screw ③ and set screw ④ firmly.

## INSTALLING AND DISMANTLING THE SEWING HOOK

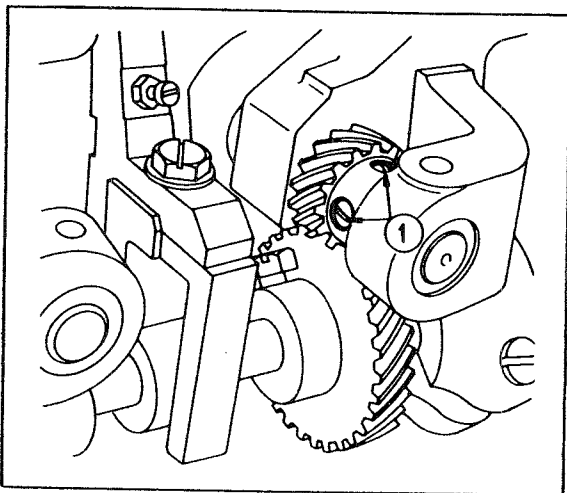

### 1. Dismantling the sewing hook

- 1) Remove the presser foot, walking foot, throat plate, feed dog and bobbin case opening lever.
- 2) Tilt the machine and loosen the set screw ① of the small gear.
- 3) Rotate the hand wheel to bring the needle bar to its highest position and remove the sewing hook by pulling it upwards.

(Note) At this point, be sure to see that the interlocking of the large gear and the small gear is not slipping.

(If the gears are marked, it will help)

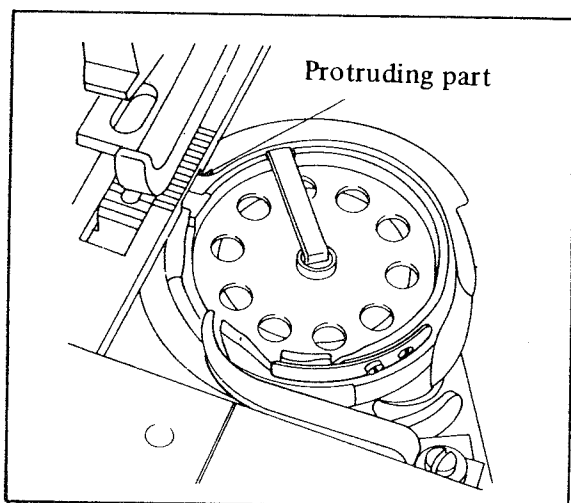

### 2. How to install the sewing hook

- 1) To install the sewing hook, reverse the dismantling procedure. In so doing, watch the following:

\*That the bobbin case opening lever link is inserted into the link pin.

\*Make the No.1 set screw of the small gear (the first screw seen when it is rotated in normal direction) enter the V-groove of the sewing hook driving shaft.

- 2) In order that the protruding part of the bobbin case holder enters the groove of the throat plate, rotate the bobbin case holder by the hand and after that, set the throat plate.

## ADJUSTING THE BOBBIN CASE OPENING LEVER

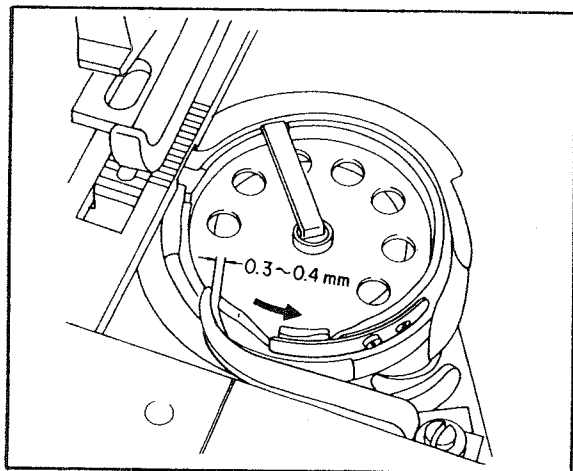

Rotate the hand wheel toward the normal direction (with the bobbin case opener in rotated condition toward the arrow direction) and as shown in the figure, when the bobbin case opening lever has retreated to the rearest position, loosen the clamp screw ① of the bobbin case opening lever and adjust so that the clearance between the bobbin case opener and the bobbin case opening lever comes to 0.3 ~ 0.4mm (3/256 ~ 1/64").

## HEIGHT OF THE PRESSER FOOT

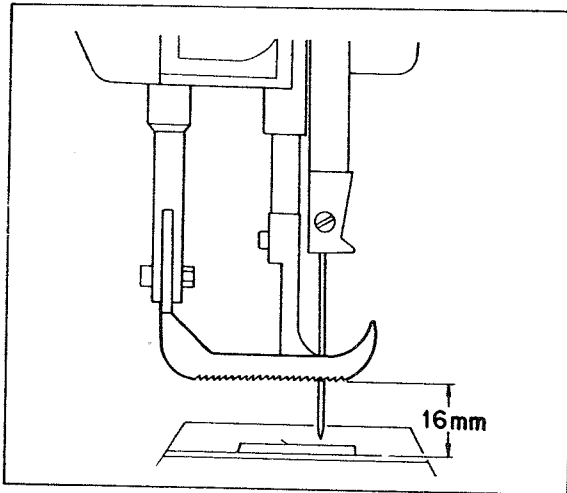

Raise up the knee lifter.

The presser foot will go up 16mm(5/8") from the surface of the throat plate and stops. When this height is less than 16mm(5/8"):

1. With the knee lifter in raised up condition, loosen the set screw ① of the knee lifter mounting bracket, insert a wooden block of 16mm(5/8") between the presser foot and the throat plate and in that condition, tighten the set screw ① of the knee lifter mounting bracket.
2. Remove the wooden block.

\*Maximum rising amount of the presser foot by means of the knee lifter is 16mm (5/8").

## INSTALLING POSITION OF THE PRESSER FOOT

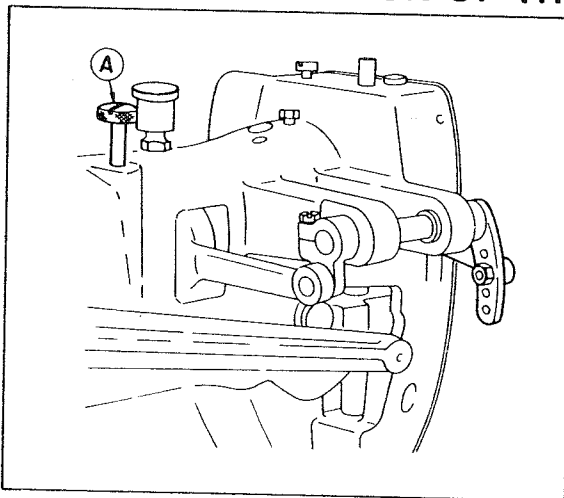

When the presser foot hits the walking foot or the needle, adjust as follows:

1. Loosen the pressure regulating thumb screw A.
2. If the presser foot is lowered and screw ① and ② are loosened, the presser bar will rotate freely.
3. Adjust the position of the presser foot and by determining the position of the needle and the needle hole of the walking foot and tighten the screw ①.
4. After these adjustments if the presser foot does not go up or down smoothly, loosen the set screw of the presser bar guide sleeve B, rotate the presser bar guide sleeve to right and left and by bringing the presser foot to the position where it will go up and down smoothly, tighten the set screw.

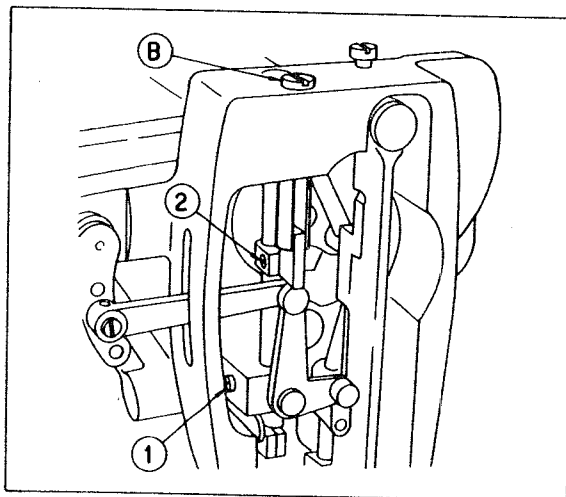

## ADJUSTING THE STITCH LENGTH

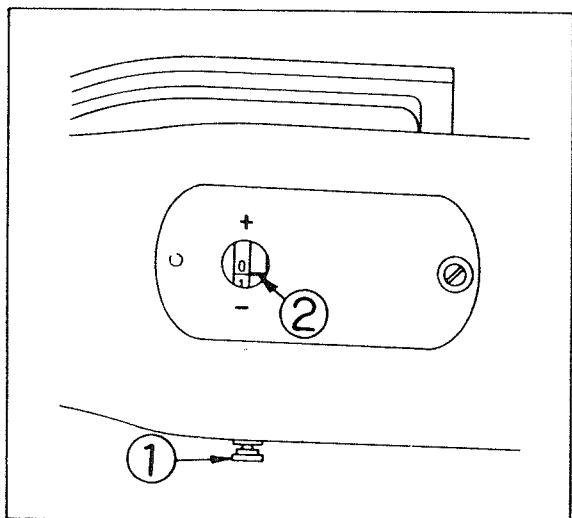

While pushing the feed adjusting button ①, rotate the hand wheel and when the end of the button has entered the groove of the cam, rotate the hand wheel fore and aft while the feed adjusting button ① is being pushed, until the desired figure of the graduator plate is matched with the carved line ② of the feed adjuster.

When the desired figure and the carved line ② are matched, release the feed adjusting button. The figure indicates the length of the stitch in mm unit. (10 → stitch length = 10mm(25/64")). The figure on the graduation plate can be seen from the sight window even with the top cover in closed condition.

## ADJUSTING THE HEIGHT OF THE FEED DOG

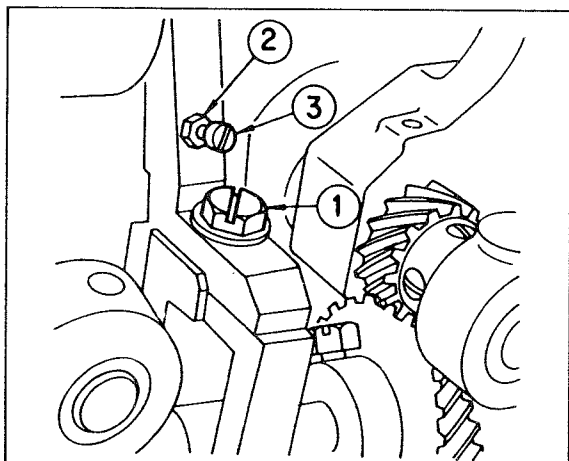

The maximum height of the feed dog above the throat plate is 1.2~1.4mm(3/64~1/16"). Adjust to this position by loosening the screw ①.

\*When the feed dog is exchanged, be sure to tighten the ② set screws of the feed dog firmly. Further, loosen nut ②, tighten screw ③ so that screw push up the feed dog lightly and tighten the nut ②.

\*In case the height of the feed dog does not become parallel, adjust by screw ③.

## ON REVERSE SEWING

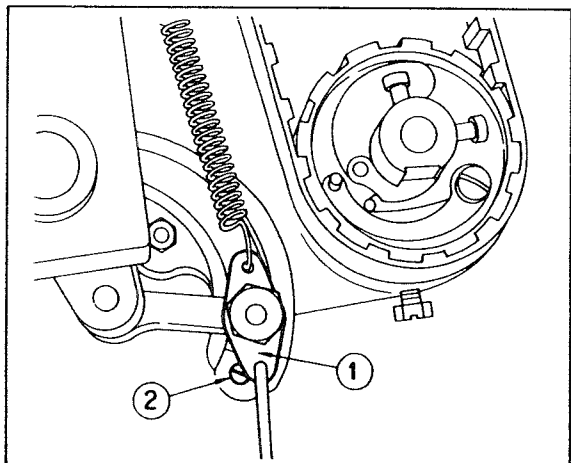

Hang the chain to the lifting crank link spring latch plate ① with a hook and catch the other end of the chain to the pedal.

When reverse sewing is to be performed, step on this pedal until the variable speed link hits the stopper ②.

## ADJUSTING THE PRESSER FOOT AND THE WALKING FOOT

- 1) When the lifting amount of the presser foot and the walking foot is to be made equal:
    1. Lower the presser foot and loosen the clamp screw ① of the upper feed spring rod.
    2. Rotate the hand wheel in the normal direction and when the lower surface of the presser foot and walking foot come to the same position as the surface of the throat plate, tighten the clamp screw ①.
  - 2) When the walking foot is to be raised higher than the presser foot:
    1. Lower the presser foot, rotate the hand wheel in the normal direction and when the lower surface of the presser foot and walking foot come to the same position as the upper surface of the throat plate, loosen the set screw of the upper feed spring rod.
    2. Then, rotate the hand wheel toward the normal direction and firmly tighten the clamp screw.
  - 3) When the presser foot is to be raised higher than the walking foot:
    1. Lower the presser foot, rotate the hand wheel in the normal direction and when the upper surface of the presser foot and walking foot come to the same position as the upper surface of the throat plate, loosen the screw of the feed rod, adjust as follows:
    2. Then rotate the hand wheel toward the reverse direction and firmly tighten the clamp screw.
- \*In both cases of 2) and 3) above, after the set screw of the upper feed spring rod is loosened, the more the hand wheel is rotated in the normal or reverse direction, the difference of the lifting amount of the presser foot and the walking foot gets larger.

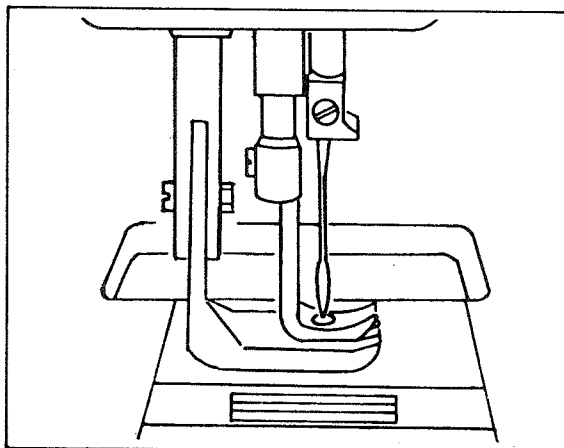
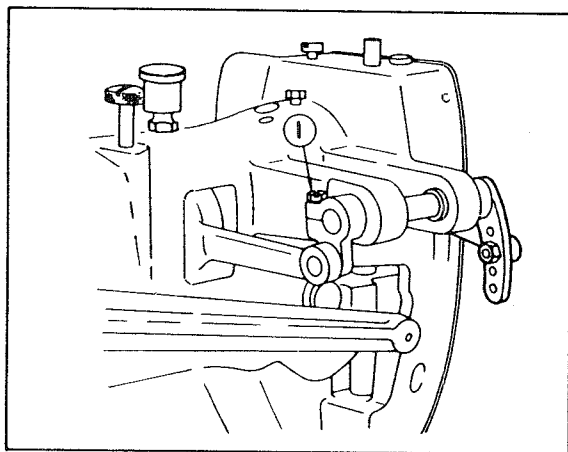

## ADJUSTING THE LIFTING AMOUNT OF THE PRESSER FOOT AND THE WALKING FOOT

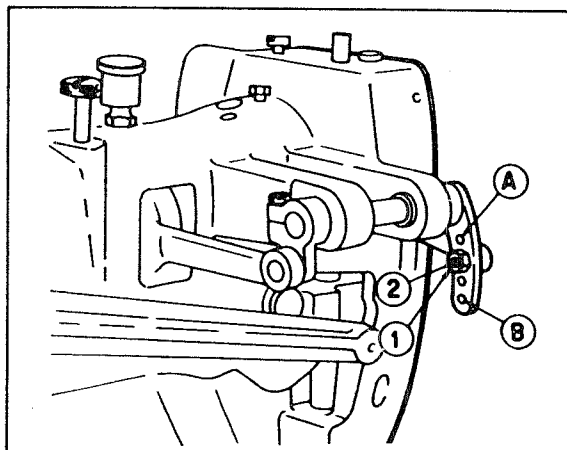

The lifting amount of the presser foot and the walking foot is adjusted according to the thickness of the sewing cloth. To make this adjustment, remove the feed adjusting screw nut ① with a spanner and by changing the position of the hole of the feed adjusting screw ②, the lifting amount changes.

The adjustment can be done in 4 steps. If it's positioned to screw hole A of topmost position, the lifting amount becomes maximum and if it's positioned to the screw hole B of bottom position, the lifting amount becomes minimum. After this adjustment, securely tighten the nut ①.

## HOW TO REMOVE THE BOBBIN CASE HOLDER

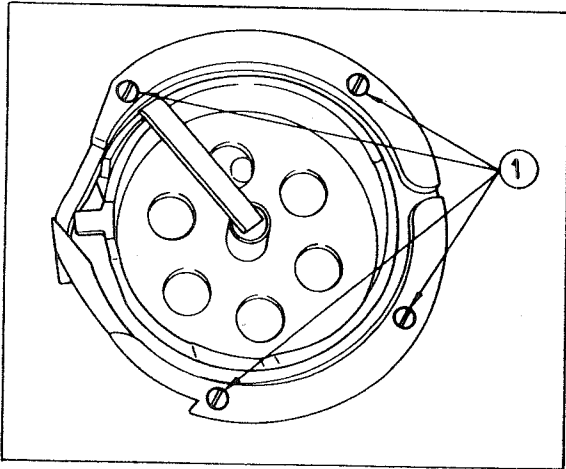

Remove the set screws ① of the left and right bobbin case pressers and pull out the bobbin case holder.

## EXCHANGING THE TIMING BELT

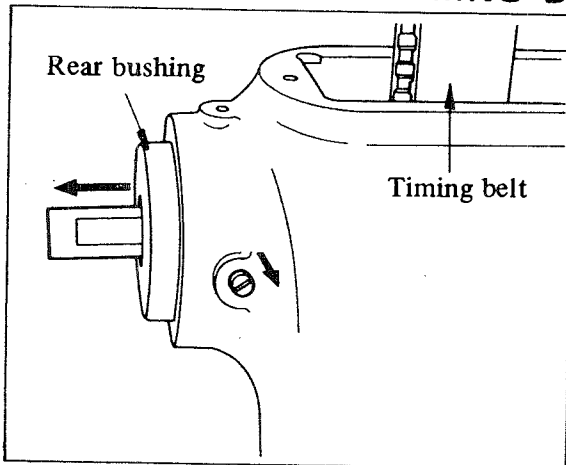

1. Remove the timing belt from the sprocket.
2. Remove the hand wheel.
3. Loosen the set screw of the rear bushing and pull out the main shaft rear bushing but be careful not to damage the bushing.
4. Pull out the timing belt from the hole from which the bushing was pulled out.
5. Install the new belt in the reverse order.

## TIMING OF MAIN SHAFT AND HOOK SHAFT

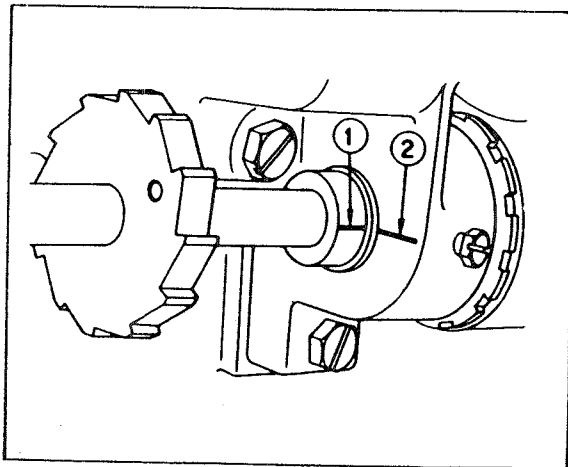

When the timing belt is removed or exchanged, match the timing of the main shaft and the hook shaft as follows:

1. Place the thread take-up at the highest dead point.
2. Match the carved line of the sewing hook thrust guard with the red carved line of the belt.
3. With this condition, pass the timing belt to the lower sprocket.

## ADJUSTING THE FORE & AFT POSITION OF NEEDLE BAR ROCKER FRAME

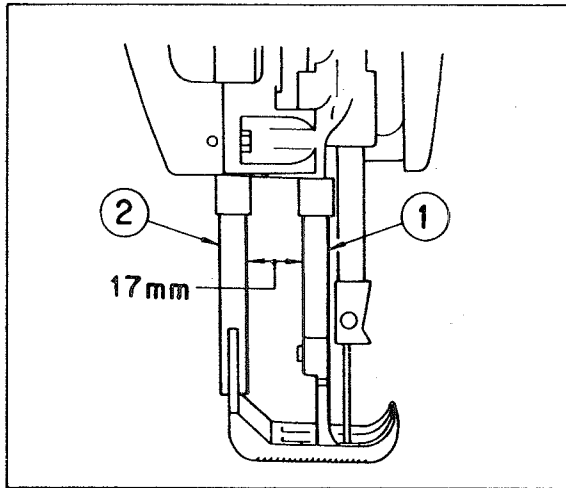

The correct distance between the walking foot bar ① and the presser bar ② is 17mm(43/64") at the place shown in the figure when the stitch length is "0".

1. Set the stitch length to "0".
2. Loosen the needle bar driving crank clamp screw ③.
3. Then, by making the clearance between the walking bar and the presser bar to 17mm(43/64"), tighten the screw ③.

### Adjust the relationship between the needle and the feed dog needle hole as follows:

1. Set the stitch length to "0".
2. Loosen the clamp screw ④ of the feed rock shaft crank.
3. Then, by bringing the needle to about the center or nearer to front from the center of the needle hole of feed dog, tighten the feed rock shaft crank clamp screw.

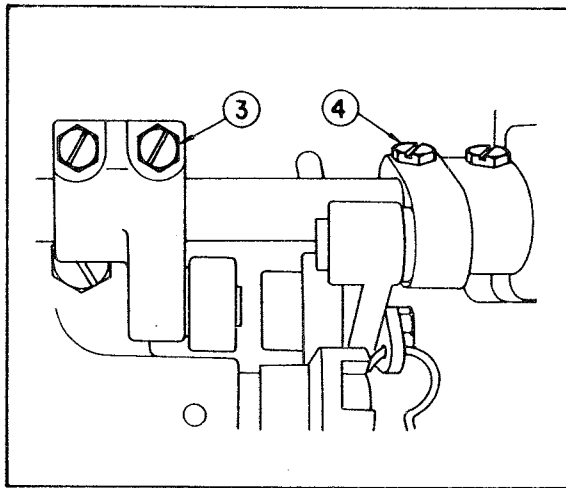

## MALFUNCTIONS, CAUSES & CORRECTIVE MEASURES

Malfunctions	Causes	Corrective measures
<p>A. Needle thread breakage.</p> <p>1. Needle thread ravel and wears out.</p>	<p>① Bruise on thread path, needle point, blade point of sewing hook and groove of bobbin case holder rotation stopper on backside of throat plate.</p>	<p>① Polish off the bruise of blade point of hook with a fine mesh paper file. Finish the groove part of throat plate by buffing.</p>
	<p>② Tension of needle thread is too strong.</p>	<p>② Refer to the chapter on "THREAD TENSION".</p>
	<p>③ Hardly no clearance between bobbin case opening lever and bobbin case holder.</p>	<p>③ Loosen the set screw of the bobbin case opening lever and make the clearance between bobbin case opening lever and bobbin case holder to 0.4 mm(1/64"). (Refer to the chapter on "ADJUSTING THE BOBBIN CASE OPENING LEVER".)</p>
	<p>④ Needle and the sewing hook are hitting each other.</p>	<p>④ Tap the hook driving shaft saddle lightly and adjust the clearance between the needle and the blade point of the sewing hook.  (Refer to the chapter on "RELATIONSHIP BETWEEN THE NEEDLE AND THE SEWING HOOK").</p>
	<p>⑤ The oil supply to the sewing hook is insufficient.</p>	<p>⑤ Adjust the oiling amount to the sewing hook.</p>
	<p>⑥ Needle is too fine against the using thread.</p>	<p>⑥ Refer to the chapter on "STANDARD STITCHING SPECIFICATIONS".</p>
<p>2. Thread breaks at step-sewing part.</p>	<p>① Lifting amount of presser foot and walking foot is too small.</p>	<p>① Increase the lifting amount of presser foot and walking foot. (Refer to the chapter on "ADJUSTING THE LIFTING AMOUNT OF PRESSER FOOT AND WALKING FOOT").</p>
<p>3. Due to inferior quality of the needle thread</p>	<p>① When the twist has flows and knots or constrictions are formed</p>	<p>① Exchange the thread</p>
	<p>② When old threads are used, sometimes they break easily with slight pressure</p>	<p>② Exchange with new thread</p>