

MODEL LH-1152-4

2-NEEDLE, NEEDLE FEED LOCKSTITCHER WITH AUTOMATIC THREAD TRIMMER

INSTRUCTION BOOK

Before operating your JUKI Lockstitch Machine, please read this Instruction Book carefully in order to operate it in the correct and efficient manners.

BEFORE OPERATION

1. Don't run the machine before filling the oil reservoir with the prescribed lubricating oil.
2. After setting up your machine, make sure that it runs in the correct direction; lower the needle by turning the handwheel and watch the handwheel's revolution by momentarily switching the power "on" (correct rotational direction of the handwheel: counterclockwise when viewed from the handwheel's end).
3. Run the newly installed machine at a speed of 4,000 s.p.m. or lower for the first 4 weeks.
4. Don't hold the machine by its synchronizer behind the handwheel when you move the machine head for installation.
5. Confirm the ratings of your power source by the machine plate stuck on the motor (power voltage, phase etc.).

CAUTIONS IN OPERATION

1. Don't put your hand under the needle when you turn the main switch "on" or operate the machine.
2. Don't put your fingers into the thread take-up cover.
3. Don't forget to turn the main switch "off" before you tilt the machine head back or remove the V-belt.
4. Never bring your fingers or hair close to, or place anything on the handwheel, V-belt, bobbin winder wheel or motor during operation. It may lead to serious personal injuries.
5. If your machine is provided with a belt cover, finger guard and eye guard, never operate your machine with any of them removed.

SPECIFICATIONS

Stitch specification	A	S	G	C
Fabrics	Light-weight	General fabric medium-weight	Denim	Chemical shoes
Sewing speed	See "35. Table of sewing speed for needle gauges" (p.10)			
Stitch length (max.)	4 mm (5/32")		6 mm (15/64")	4 mm (5/32")
Needle	Sg x 1906 #9 ~ #11	DP x 5 #11 ~ #22	DP x 5 #18 ~ #22	
Needle gauge	3/32" ~ 1-1/4" (2.4 mm ~ 31.8 mm)	1/8" ~ 1-1/4" (3.2 ~ 31.8 mm) (1/8" on special request)	3/16" ~ 1-1/4" (4.8 mm ~ 31.8 mm)	3/32" ~ 1/4" (2.4 mm ~ 6.4 mm)
Presser foot lift	6 mm (15/64") by hand lifter, 10 mm (25/64") by knee lifter			
Lubricating oil	JUKI New Defrix Oil No. 2 (Oil for Overedger)			

1. INSTALLATION

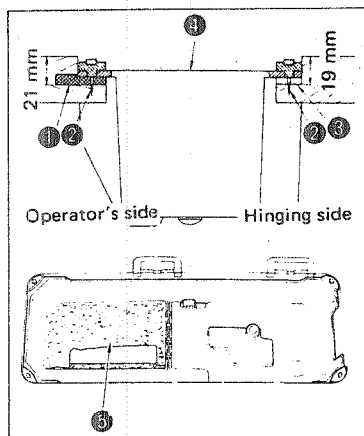

★ Attaching the oil reservoir:

Nail rubber cushions ① on two corners on the operator's side using nails ②, nail felt cushions ③ on the two corners on the hinging side using nails ② and place oil reservoir ④ in the way that it is supported by these four corners.

Place foamed polyurethane pad ⑤ on the bottom of the oil reservoir.

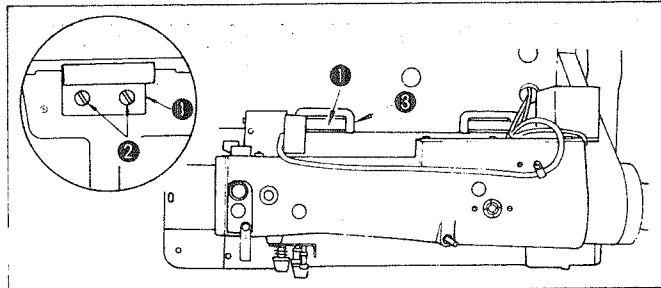

Fasten hinge ① to the bed surface using flush-head screws ② and place the head on the rubber cushions on four corners by engaging the hinge with rubber hinge ③ on the table.

2. LUBRICATION

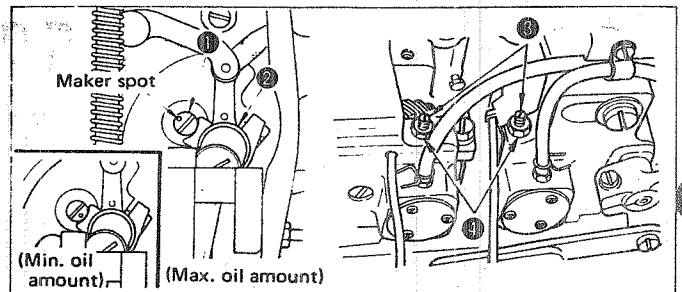
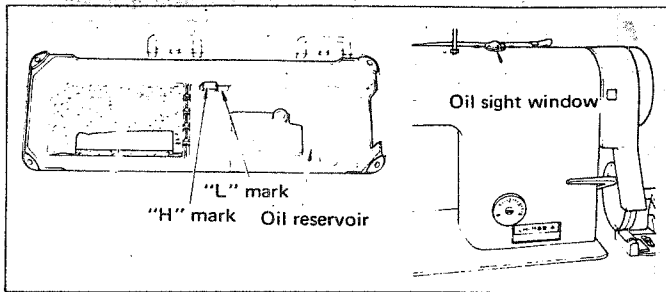

★ Before operating machine:

1. Pour the JUKI New Defrix Oil No. 2 into the oil reservoir up to "H" mark.
2. Add the same lubricating oil as soon as the oil level has come down to the "L" mark level.
3. Run the machine and make sure that the oil splash is seen in the oil sight window. (more than 1,000 s.p.m.)
4. Take note that, when the ambient temperature drops down to 5°C or lower, the amount of lubricating oil supplied to the face plate components will become smaller and to the contrary, more amount of oil will be fed to the sewing hooks. So, adjust their oil regulating screws properly. Also when you use the lubricating oil of other trade names, check for the lubrication on these components after the first 30 minute's operation and adjust the above-mentioned screws when necessary.

(CAUTION) Before operating newly installed machines or machines which have not been used for a relatively long period of time, let them idle for about 10 minutes at 3,000 to 3,500 s.p.m.

★ Adjustment of oil amount for the face plate components:

Amount of lubricating oil supplied to the face plate components such as thread take-up lever and needle bar crank is adjustable by turning adjusting pin ①: bring the marker spot engraved on the adjusting pin close to needle bar crank ② to minimize or farthest from the needle bar crank to maximize the amount of oil.

★ Adjustment of oil amount for the hook;

Loosen nut ④ and turn adjusting screw ③ clockwise to increase or counterclockwise to reduce the amount of oil fed to the hook.

(CAUTION) In order to prevent adjusting screw ③ from breakdown, gently tighten nut ④.

3. INSTALLATION OF THREAD STAND

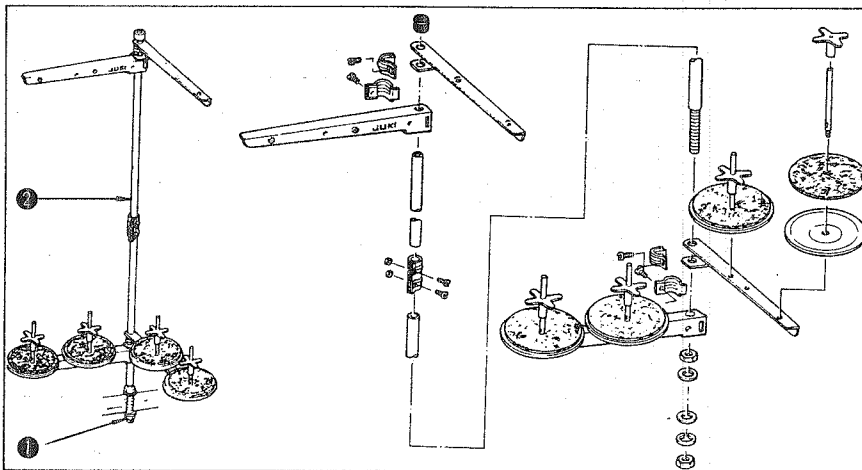

Assemble the thread stand, set it up on the machine table using the installation hole in the table and tighten nut ① gently. When you use power supplied by the overhead power line, pass the power supply cord through hollow spool rod ②.

4. ATTACHING THE BELT COVER AND THREAD WINDER

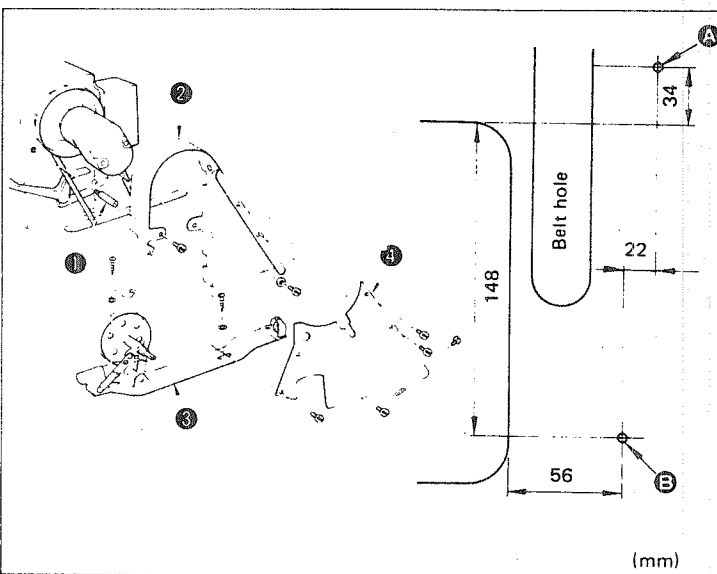

1. Make guide holes ① and ② in the table for wood screws.
2. Screw belt cover post ③ into the tapped hole in the machine arm.
3. Fix belt cover ④ to the belt cover post and then to the groove on the machine arm.
4. Put thread winder assembly ⑤ in the belt cover and adjust its position.
5. Attach top cover ⑥ to the belt cover.
6. Tilt the head back and make sure that the belt cover does not touch the table.
7. Fix the thread winder using the wood screws and guide holes ① and ②.

5. CONNECTION OF CORDS

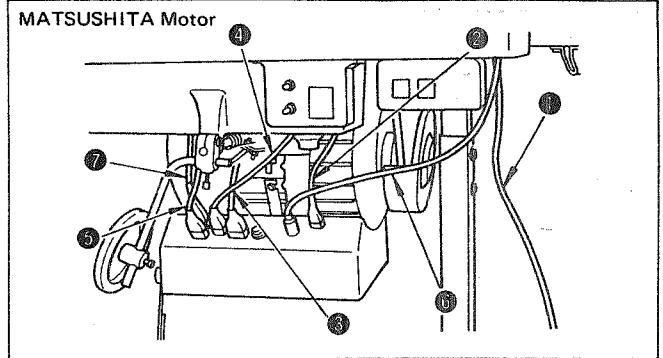
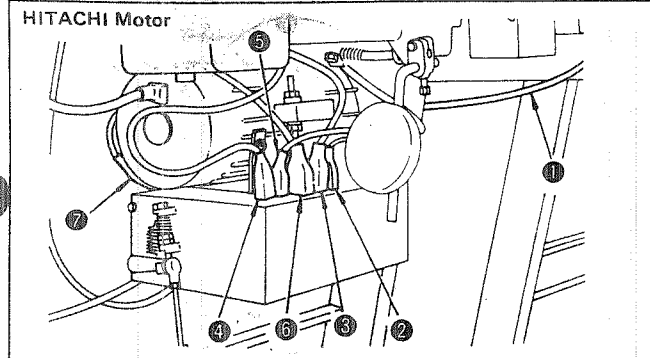

- ① : Power supply cord
- ② : Cord to Magnetic clutch brake (already connected)
- ③ : Cord to automatic reverse feed selector switch
- ④ : Cord to wiper and reverse feed switch lever
- ⑤ : Cords to thread trimmer solenoid magnet and to reverse feed solenoid magnet
- ⑥ : Cord to synchronizer
- ⑦ : Power supply cord for controller

(CAUTION) Before connecting these cords, don't forget to switch "off" the power line.
After connecting these cords, make sure that none of the cords touches the motor pulley or V-belt.

6. ATTACHING THE NEEDLES

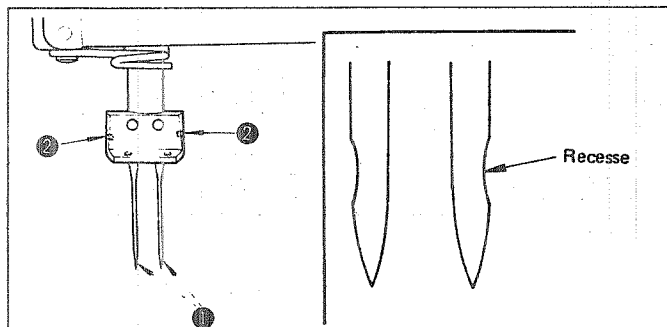

- * Switch "off" the motor.
Use Sg x 1906 needles for Specification A and DP x 5 needles for Specifications S and G.
1. Turn the handwheel until the needle bar has come up to the highest point of its stroke.
 2. Loosen needle clamp screws ② and pick up two needles ① in the way that their recesses are facing outwards.
 3. Insert the needles into the needle clamp as far as they will go.
 4. Tighten needle clamp screws ② firmly.

9. INSERTING A BOBBIN IN A BOBBIN CASE

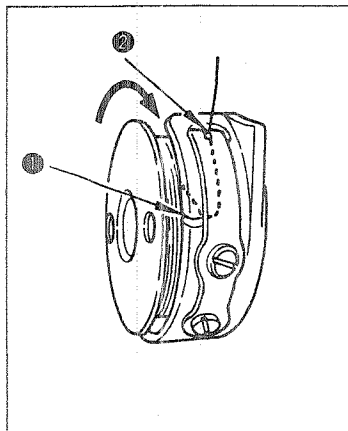

1. Hold a bobbin in the way that it seems being wound clockwise and put it in the bobbin case.
 2. Pass the thread through thread path ① in the bobbin case and draw the thread, and the thread will be brought to thread hole ② via the tension spring.
- * Make sure that the bobbin revolves in the direction of the arrow when you draw the thread.

7. HOW TO TAKE OUT THE BOBBIN CASE

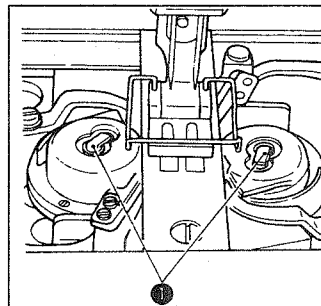

1. Lift latch ① and take out the bobbin case and the bobbin together.
2. Hold the bobbin case by latch raised, put it into the shaft in the hook correctly and release the latch.

8. WINDING THE BOBBINS (SINGLE BOBBIN WINDER)

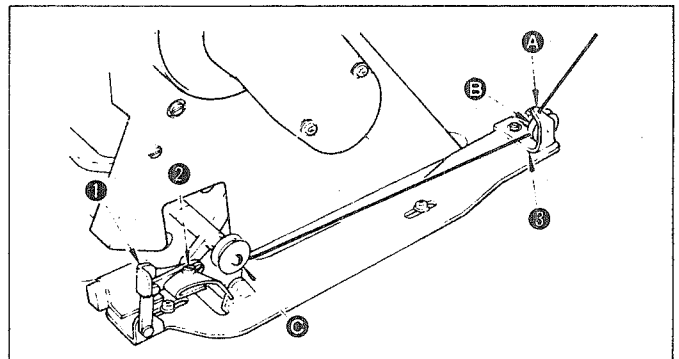

1. Take the thread end from a thread spool, pass it through the thread guides as A, B and C and wind it several turns round the bobbin.
2. Tilt bobbin presser ① permitting the thread winder pulley to touch the running belt.
3. Adjust screw ② to wind a bobbin about 80% of its capacity; turn the adjusting screw clockwise to increase or counterclockwise to reduce the amount of thread to be wound.
4. If the bobbin is wound unevenly, adjust it by moving the position of tension bracket ③ to the left or the right.
5. When the bobbin is filled up, the bobbin presser automatically releases the thread winder pulley from the running belt.

(See P. 10 for a twin bobbin winder)

10. TWIST OF SEWING THREAD

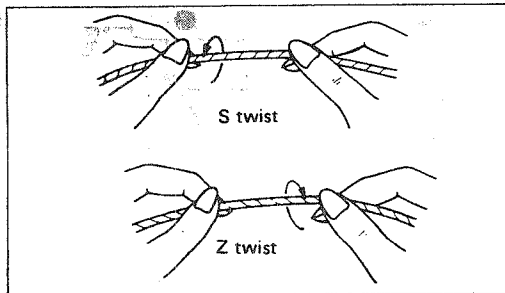

It is advisable to use the left-twist thread (S twist) for the needle on the left and the right-twist thread (Z twist) for the needle on the right. If it is not possible, use only the right-twist thread (Z twist). Either twist will do for the bobbin thread.

12. STITCH LENGTH

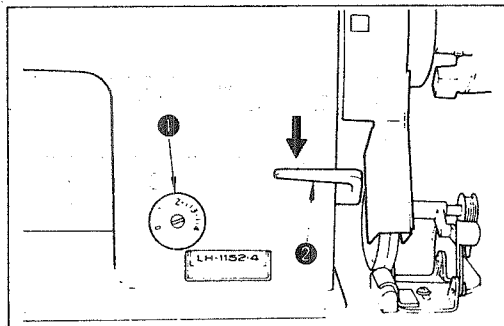

Set stitch dial ① for a desired stitch length.

★ Reverse feed operation

1. Depress reverse feed control lever ②.
2. Reverse stitches are made as long as you keep depressing the lever.
3. Release the lever, and the machine will run forward.

14. CONNECTION OF THE PEDAL

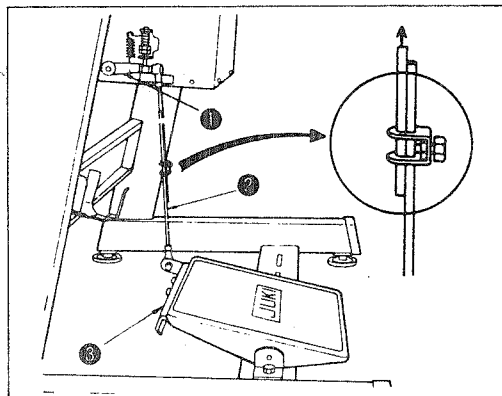

★ Attach the pedal connecting rod

Move pedal adjusting plate ③ to the left or the right to make motor control lever ① and pedal connecting rod ② straight.

★ Adjusting the slant of the pedal:

Slant of the pedal is adjustable by changing the effective length of the pedal connecting rod. Tighten firmly the clamp screw of the connecting rod after the adjustment.

11. THREADING THE MACHINE

("C" specification)

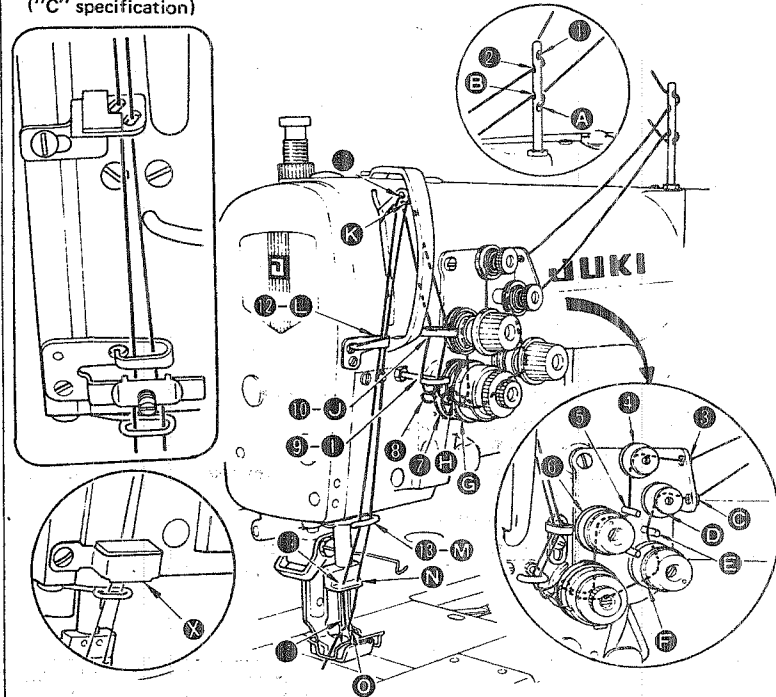

Thread the machine as illustrated.

Thread ① to ⑤ for the needle on the left.

Thread ⑥ to ⑩ for the needle on the right.

(NOTE) When you operate the thread trimmer after providing concealed seams, attach optional thread guide ⑪ (Part No. 10102259) to the face plate.

13. HOW TO OPERATE THE PEDAL

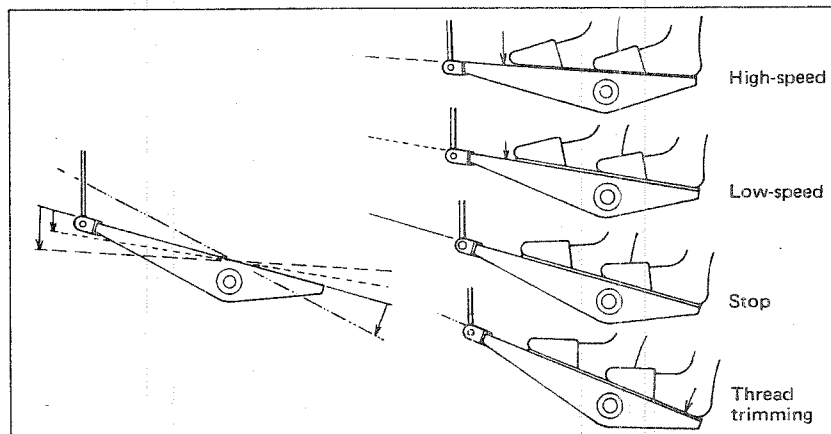

The pedal is operated in 4 stages.

1. Depress the pedal lightly forward for low-speed operation.
2. Depress the pedal further forward for high-speed operation.
3. Bring the pedal back to its initial position, and the machine will stop with the needle "up" or "down".
4. Depress the pedal backward (toe-up) for thread trimming.
 - You can depress the pedal backward for thread trimming directly from its high-speed or low-speed position.
 - You can bring the pedal back to its initial position immediately after you have confirmed the start of a thread trimming action. The machine will stop after completing a thread trimming action.
 - If you want to rise the needle which has stopped, in "down" position, depress the pedal once backward.

(NOTES) This machine is designed to permit you to select the machine to stop with the needle "up" or "down". Refer to the separate Instruction Book for the Motor for further details.

15. THREAD TENSION

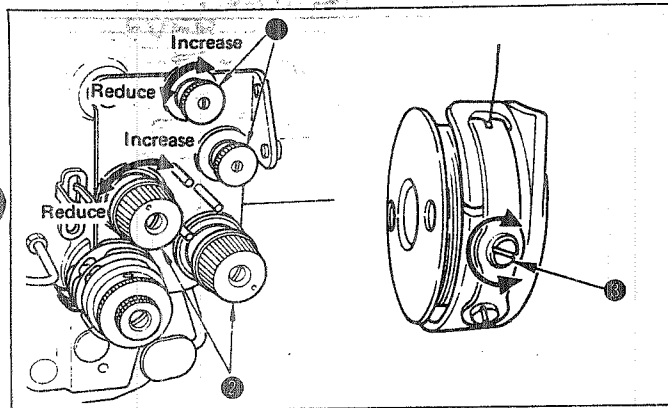

★ Needle thread tension

Turn thread tension nut No. 2 ② clockwise to increase or counterclockwise to reduce the needle thread tension. Turn thread tension nut No. 1 ① clockwise to increase or counterclockwise to reduce the length of the thread left in the needle after thread trimming.

★ Bobbin thread tension

Turn tension adjusting screw ③ clockwise to increase or counterclockwise to reduce the bobbin thread tension.

17. HAND LIFTER

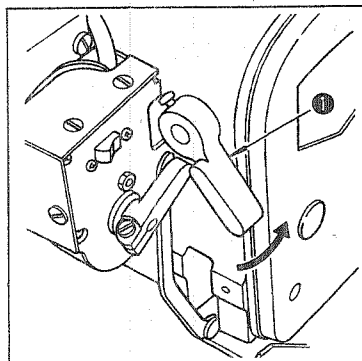

When you want to keep the presser foot in the lifted position, turn hand lifter ① in the direction of the arrow. By so doing the presser foot will rise 6 mm (15/64") and stay until the hand lifter is lowered.

Operate the knee lifter, and the presser foot will rise 10 mm (25/64") from its working level.

19. RELATION BETWEEN THE MAIN SHAFT AND THE HOOK DRIVING SHAFT

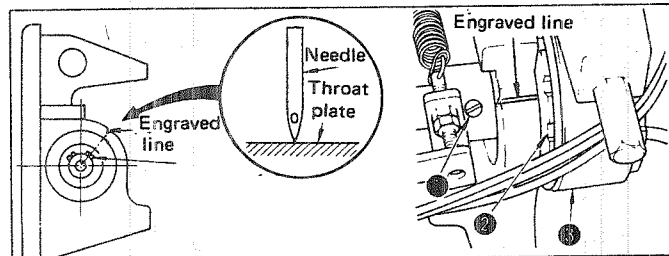

Relation between the main shaft and the hook driving shaft is determined by the timing belt. If you replace or remove the timing belt from the shaft for repair or adjustment of the related parts, you must position the timing belt exactly in the following way;

1. Set the stitch dial to "0".
2. Turn the handwheel in the normal direction until the pointed end of the needle had come down to the level of the throat plate.
3. Turn the hook driving shaft in the normal direction until the center of No. 1 setscrew ① of the hook driving shaft thrust collar aligns with the engraved line on the bed.
4. Put timing belt ③ on lower sprocket wheel ② taking care not to move the hook driving shaft and the main shaft from the above-mentioned position.

16. THREAD TAKE-UP SPRING

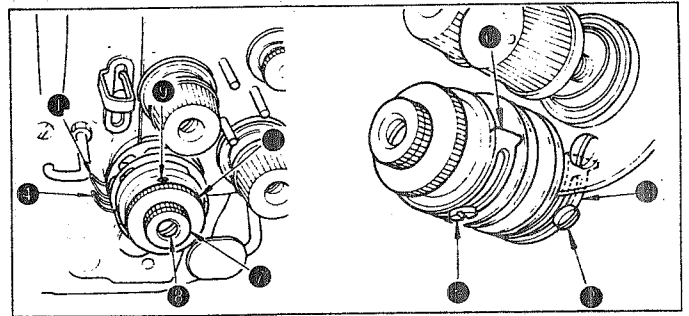

★ When you want to change the stroke of the spring:

1. Stroke of take-up spring ④ on the left is adjustable by moving stopper ③ to the left or the right after loosening stopper setscrew ②.
2. Stroke of take-up spring ④ on the right is adjustable by moving stopper ⑥ to the left or the right after loosening stopper setscrew ⑤.
3. Move the stopper to the right to increase or to the left to reduce the stroke of the take-up spring.

★ When you want to change the tension of the spring:

1. Tension of the take-up spring on the left is adjustable by turning stud ⑧ counterclockwise to increase or clockwise to reduce after loosening nut ⑦.
2. Tension of the take-up spring on the right is adjustable by turning spring guide ⑩ clockwise to increase or counterclockwise to reduce after loosening setscrew ⑨.

18. ADJUSTMENT OF THE PRESSURE OF THE PRESSER FOOT

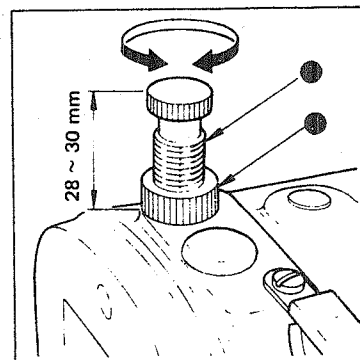

Loosen nut ② and turn presser spring regulator ① clockwise to increase or counterclockwise to reduce the pressure of the presser foot. Tighten nut ② after the adjustment. When sewing general fabrics, adjust the height of the head of the presser spring regulator to 28 to 30 mm (1-7/64" to 1-3/16") The height is equivalent to approx. 5 Kg.

20. ADJUSTING THE FEED TIMING

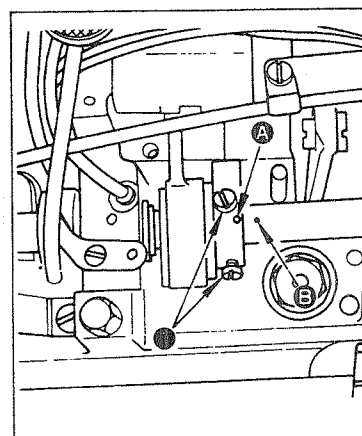

The feed eccentric must be fixed in phase with the hook driving shaft.

1. Loosen screws ① which set the feed eccentric guide.
2. Align engraved marker spot A on the feed eccentric with marker spot B on the hook driving shaft.

(CAUTION)

When adjusting the feed eccentric, take care not to move it in the axial direction. Because it may increase the load.

21. HEIGHT OF THE FEED DOG

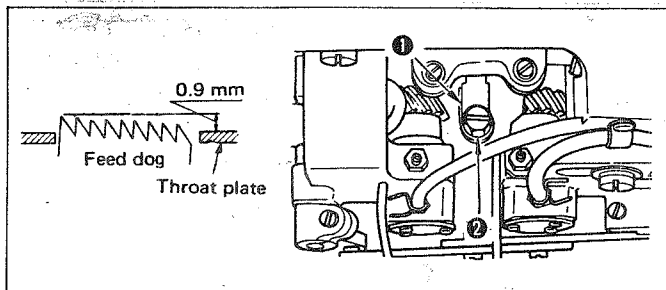

The feed dog must protrude its teeth 0.9 mm from throat plate surface when it has come up to the highest point of its trajectory.

1. Set the stitch dial to "0".
2. Turn the handwheel in the normal direction to bring the feed dog to the highest point.
3. Loosen screw ② and adjust the height of the feed dog to 0.9 mm by moving feed bar slide fork ①.

22. TIMING TO RELEASE THE THREAD TENSIONS

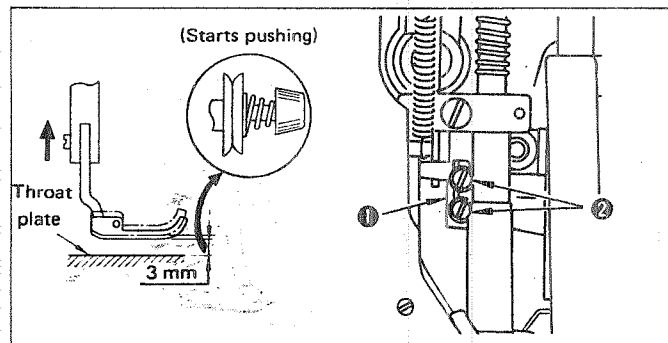

1. Raise the presser foot 3 mm (1/8") from the throat plate surface by the hand lifter.
2. Loosen screws ② and adjust the height of thread tension release link (B) ① in the way that the link starts pushing the tension disc away to release the thread.

23. NEEDLE-TO-HOOK RELATION

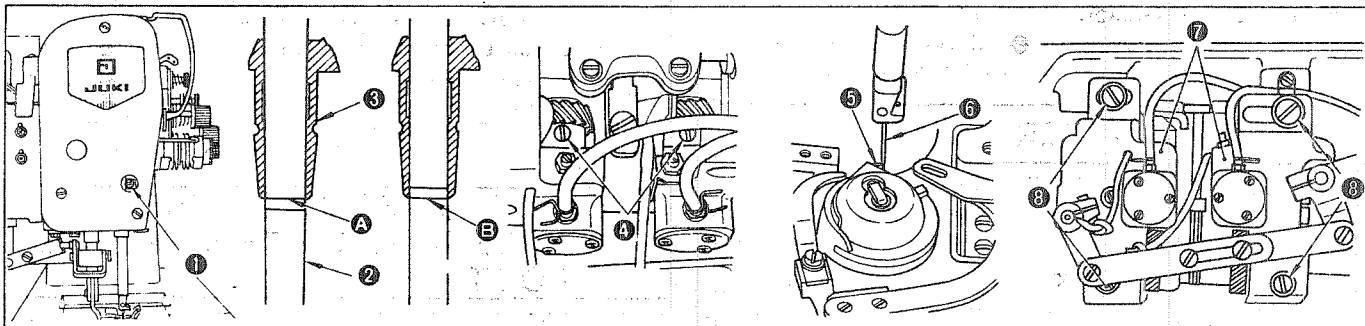

★ Set the needle to hook relation in the following way:

1. Set the stitch dial to "2".
2. Turn the handwheel to bring the needle bar to the lowest point of its stroke and loosen screw ① which clamps the needle bar connection.
(Set the needle bar height)
3. Align upper marker line A engraved on needle bar ② with the lower end of needle bar frame ③ and tighten screw ①.
(Set the hook)
4. Loosen three setscrews ④ to set free the hook shaft gear (small). Turn the handwheel until lower marker line B engraved on the needle bar meets the lower end of the needle bar frame.
5. Loosen two setscrews ③ and adjust the position of hook driving saddle ⑦ to provide a clearance 0.02 ~ 0.05 mm between needle ⑥ and hook blade point ⑤.
6. Align the hook blade point with the center of the needle and fix the hook shaft gear (small) by tightening three setscrews.

24. HOOK NEEDLE GUARD

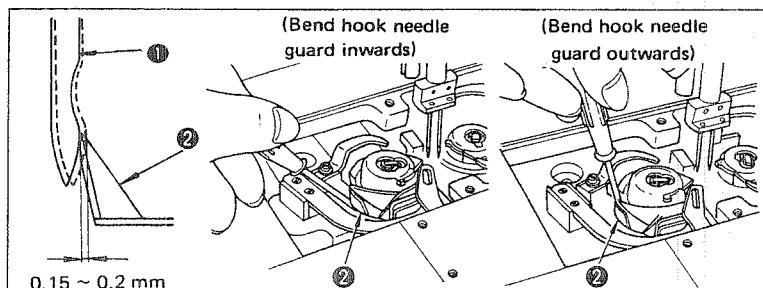

When a hook is replaced, you must adjust the working point of the hook needle guard. Hook needle guard ② must push needle ① away for 0.15 or 0.2 mm. Adjust it by carefully bending the hook needle guard.

1. If you want to bend it inwards, do it from the outside of the hook needle guard using a screw driver.
2. If you want to bend it outwards, do it from the inside of the hook needle guard using a screw driver.

25. BOBBIN CASE OPENING LEVER

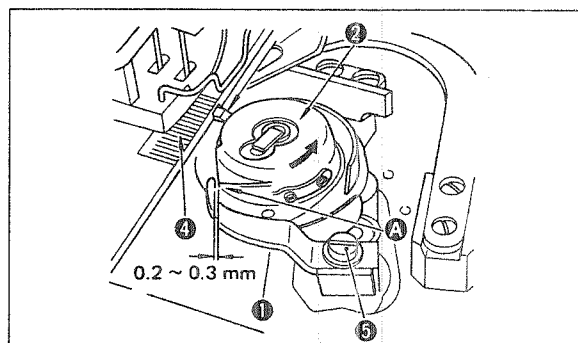

1. Turn the handwheel in the normal direction until bobbin case opening lever ① has entirely withdrawn from its working position.
2. Turn bobbin case ② in the direction of the arrow until stopper ③ rests in the groove on throat plate ④.
3. Loosen screw ⑤ and provide a 0.2 to 0.3 mm clearance between the bobbin case opening lever and protrusion A on the bobbin case.

26. AMOUNT OF THREAD TAKEN UP BY THE LEVER

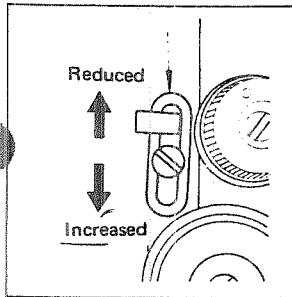

The amount of thread taken up by the thread take-up lever must be reduced when light-weight fabrics are sewn; raise thread guide ①. Inversely, lower thread guide ① when medium or heavy-weight fabrics are sewn. Note that the G specification machine has a special thread guide.

28. INITIAL POSITION OF THE MOVING KNIFE

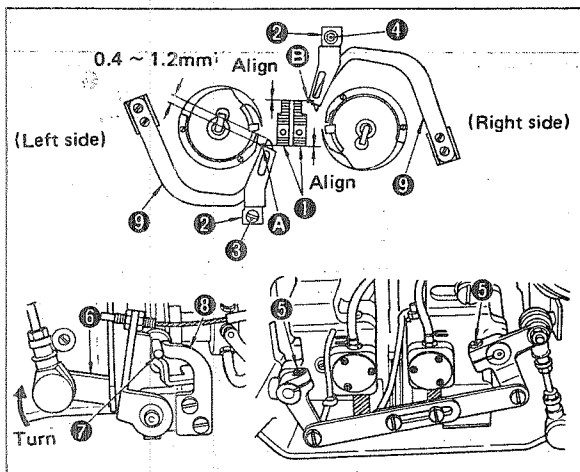

1. Using the stitch dial, set the stitch length to "0".
2. Turn the handwheel in the forward direction to bring the needle to the center of the needle hole in the feed dog.
3. Further turn the handwheel until the needle bar reaches its lowest point.
4. Loosening setscrews ⑥ and ④, make adjustment so that the edge surface of the feed dog ① aligns with A and B of fixed knife ②.
5. Loosen rocker arm clamp screw ⑤.
6. Turn cam follower ⑥ in the direction of arrow cam roller shaft ⑦ comes in the contact with stopper ③.
7. Tighten rocker arm clamp screw ⑤ when the top end of moving knife ⑨ protrudes 0.4 to 1.2 mm from A and B of fixed knife ②.
8. Turn the handwheel, let the thread trimmer operate several times and make sure that the moving knife performs its action as adjusted.

(CAUTION) Be sure to complete the positioning of the fixed knife before positioning the moving knife.

31. HOW TO RESHARPEN THE FIXED KNIFE

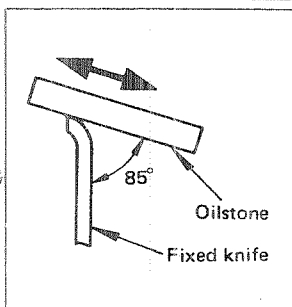

As soon as the thread trimmer knife becomes dull, sharpen the fixed knife as illustrated using an oilstone.

27. THREAD TRIMMER CAM

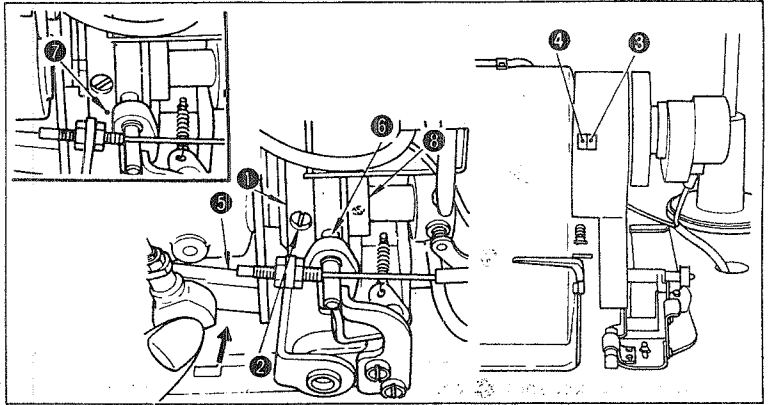

1. Loosen two screws ② which set the thread trimmer cam ①.
2. Align red marker spot ③ on the handwheel with red marker spot ④ on the machine arm.
3. Push cam follower ⑤ to let cam roller ⑥ rest in the groove on the thread trimmer cam.
4. Turn the thread trimmer cam until its marker spot ⑦ aligns with the axis of the cam roller and fix the thread trimmer cam as you are pressing the thread trimmer cam of thrust collar ⑧.

29. HEIGHT OF THE MOVING KNIFE

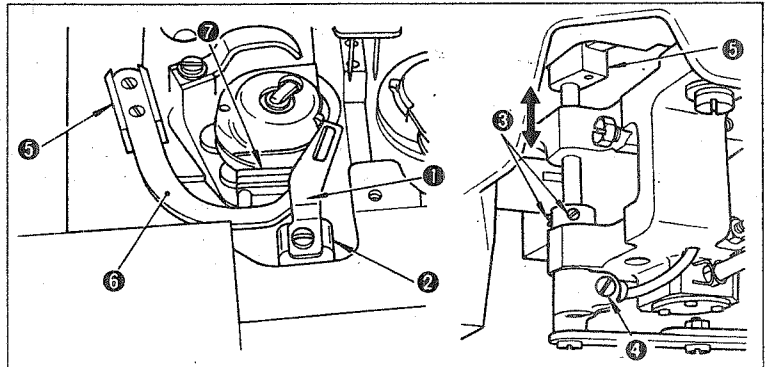

1. Remove fixed knife ① from hook shaft saddle ②.
2. Loosen screws ③ to set free the moving knife shaft thrust collar.
3. Loosen screw ④ which clamps the rocker arm.
4. Adjust moving knife link ⑤ in the vertical direction to permit moving knife ⑥ to touch moving knife rest ⑦. Tighten screw ④.

30. ADJUSTMENT OF THE PRESSURE OF THE CLAMP SPRING

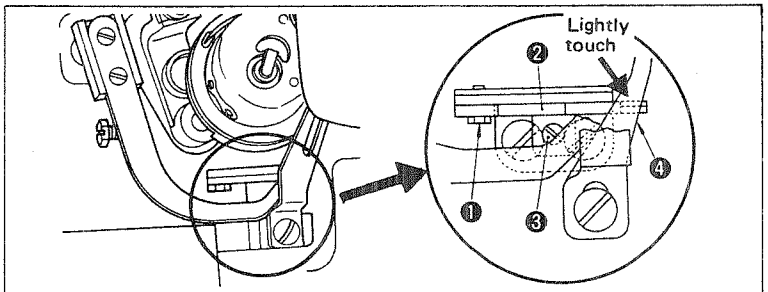

1. Loosen screw ①.
2. Screw in adjusting screw ③ until adjusting metal fittings ② lightly touches the clamp spring ④.
3. After adjustment, securely tighten screw ① to fix adjusting metal fittings ②.

(CAUTION) Be careful not to overtighten adjusting screw ③, or else and excessive spring pressure will result and inferior clamping may often occur.

32. POSITION OF THE WIPER

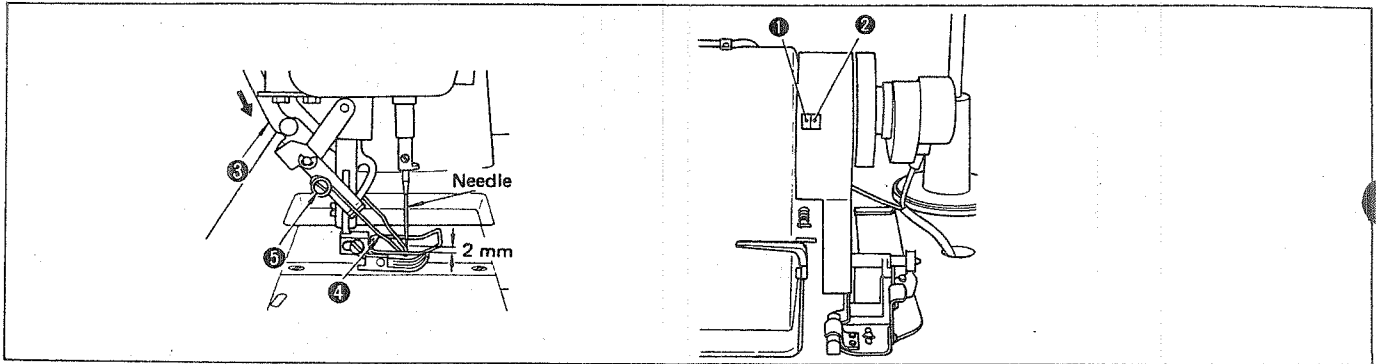

1. Align red marker spot ① engraved on the arm with white marker spot ② engraved on the handwheel.
2. Move red ③ in the arrowed direction and perform adjustment using adjusting screw ⑤ so that a clearance of 2 mm is provided between the needle and wiper ④.

33. REVERSE FEED SWITCH LEVER

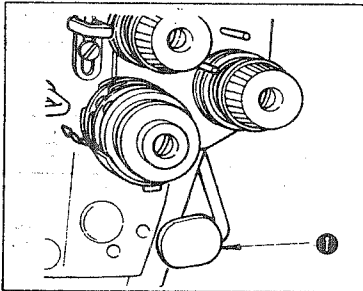

★ How to use

1. Depress switch lever ①, and the machine will immediately run in the reverse direction.
2. Reverse stitch is made as long as you keep depressing the switch lever.
3. Release the switch lever for forward sewing.

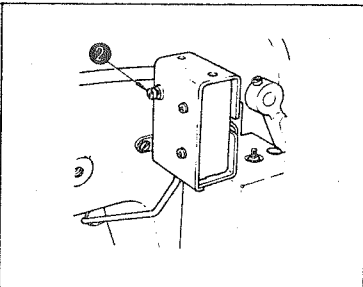

★ Height of the switch lever

Adjust the height of the switch lever for your convenience. Loosen screw ② and adjust the height as desired.

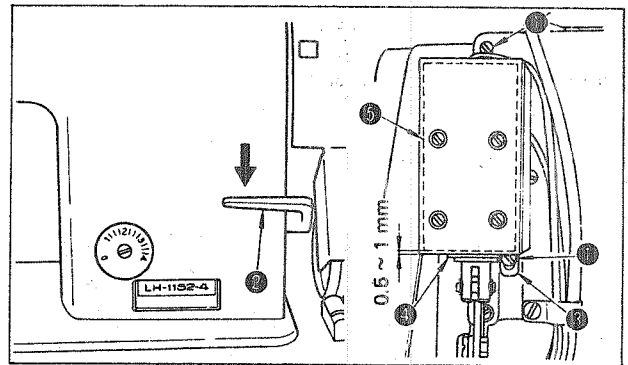



★ Position of the reverse feed solenoid

1. Set the stitch dial to the maximum value.
2. Loosen screws ① which fix the solenoid in place.
3. Depress reverse feed control lever ② fully downwards, provide a 0.5 to 1.0 mm (1/64" to 3/64") clearance between solenoid ⑤ and rubber packing ④ on the plunger by moving solenoid bracket ③ up and down and tighten screws ①.

34. GAUGE SETS

★ Table of gauge sets

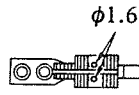
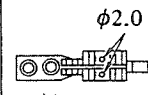
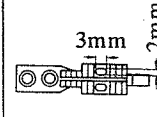
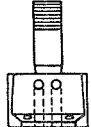
Code	Needle gauge		Throat plate			Feed dog			Needle clamp
	inch	mm	 (For 4mm long stitch)	 (For "C" specification)	 (For 6mm long stitch)	 φ1.6	 φ2.0	 3mm 2mm	
A	3/32	2.4	○	○	/	○	/	/	○
B	1/8	3.2	○	○	/	○	○	/	○
C	5/32	4.4	○	○	○	○	○	*	○
D	3/16	4.8	○	○	○	○	○	○	○
E	7/32	5.6	○	○	*	○	○	○	○
F	1/4	6.4	○	○	○	○	○	○	○
G	9/32	7.1	○	/	*	○	○	○	○
H	5/16	7.9	○	/	○	○	○	○	○
K	3/8	9.5	○	/	○	○	○	○	○
W	7/16	11.1	○	/	*	○	○	○	○
L	1/2	12.7	○	/	○	○	○	○	○
M	5/8	15.9	○	/	○	○	○	○	○
N	3/4	19.1	○	/	○	○	○	○	○
P	7/8	22.2	○	/	○	○	○	○	○
Q	1	25.4	○	/	○	○	○	○	○
R	1 1/8	28.6	○	/	○	○	○	○	○
S	1 1/4	31.8	○	/	○	○	○	○	○
"S" specification			★	/	/	/	★ (Needle #11~#20)	☆ (Needle #18~#22)	Common to all specifications (No difference)
"A" specification			★	/	/	★	/	/	
"G" specification			/	/	★	/	/	★	
"C" specification			/	★	/	/	★	/	

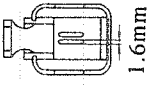
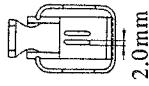
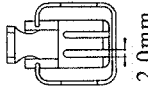
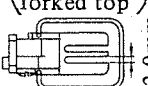
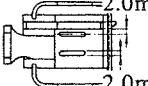
Code	Needle gauge	Presser foot					Bed side (left & right)	Hook driving shaft rivins (front & intermediate)	Wiper Wiper base
		 1.6mm	 2.0mm	 (Forked top) 2.0mm	 (Locomobile forked top) 2.0mm	 (Swivel-guide) 2.0mm			
A	3/32	○	/	/	●	/	←	←	←
B	1/8	○	*	/	○	*	←	←	←
C	5/32	○	○	*	○	*	←	←	←
D	3/16	○	○	○	○	*	←	←	←
E	7/32	○	○	*	○	*	←	←	*
F	1/4	○	○	○	○	○	←	←	←
G	9/32	○	○	*	○	*	←	←	←
H	5/16	○	○	○	○	○	←	←	←
K	3/8	○	○	○	○	*	←	←	←
W	7/16	○	○	*	○	*	←	←	←
L	1/2	○	○	○	/	*	←	←	*
M	5/8	○	○	○	/	*	←	←	*
N	3/4	○	○	○	/	*	←	←	*
P	7/8	○	○	○	/	*	←	←	*
Q	1	○	○	○	/	*	←	←	*
R	1 1/8	○	○	○	/	*	←	←	*
S	1 1/4	○	○	○	/	*	←	←	*
S		/	★	☆	☆	☆	Common to all specifications (No difference)		
A		★	/	/	/	/			
G		/	☆	★	☆	☆			
C		/	/	☆	★	☆			

★ Standard specifications ☆ Non-standard specifications * Specially manufactured upon request

35. TABLE OF SEWING SPEED FOR NEEDLE GAUGES

Specification	Needle gauge	Stitch length	Sewing speed (Max.)	Sewing speed (normal)
S	1/8" ~ 3/8" (3.2 ~ 9.5mm)	4mm	4,500 s.p.m.	4,000 s.p.m.
	7/16" ~ 3/4" (11.1 ~ 19.1mm)		3,800	3,500
	7/8" ~ 1-1/4" (22.2 ~ 31.8mm)		3,500	3,200
G	3/16" ~ 3/8" (4.8 ~ 9.5mm)	4mm	*4,500	4,000
		4 ~ 6mm	4,000	3,800
	7/16" ~ 3/4" (11.1 ~ 19.1mm)	4mm	3,800	3,500
		4 ~ 6mm	3,500	3,200
	7/8" ~ 1-1/4" (22.2 ~ 31.8mm)	4mm	3,500	3,200
		4 ~ 6mm	3,200	3,000
A	3/32" ~ 3/8" (2.4 ~ 9.5 mm)	4mm	4,000	3,800
	7/16" ~ 3/4" (11.1 ~ 19.1mm)		3,500	3,200
	7/8" ~ 1-1/4" (22.2 ~ 31.8mm)		3,200	3,000
C	3/32" ~ 1/4" (2.4 ~ 6.4 mm)	4mm	3,000	2,800

* The maximum sewing speed is 4,000 s.p.m. when you sew denim heavier than 12 oz.

(Notes) The above sewing speed are based on the average sewing conditions.

You are requested to determine an optimum speed depending on the kinds of materials and sewing process.

36. HOW TO ADJUST THE SYNCHRONIZER

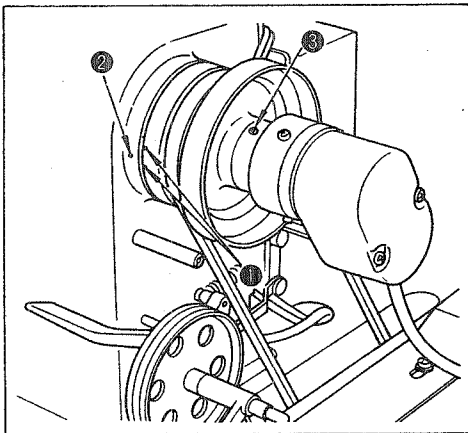

(Attaching the synchronizer)

1. Attach the synchronizer to the handwheel.
2. Let the machine perform thread trimming action and adjust the position of the synchronizer by loosening its setscrews (3) so that the handwheel stops with its two white marking spots (1) surrounding in the middle a red marking spot (2) engraved on the machine arm.

(Notes) Accurately position it through your trial sewing.

37. WINDING THE BOBBINS (TWIN BOBBIN WINDER) (SPECIAL ORDER)

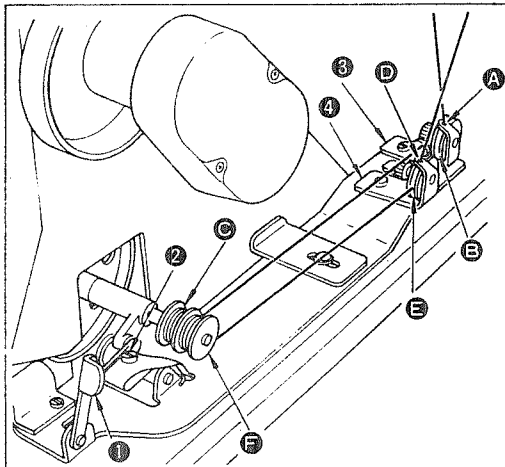

1. Take the thread end from a thread spool, pass it through the thread guides (A), (B) and (C) in that order for an inside bobbin or the thread guides (D), (E) and (F) for an outside bobbin and wind it several turns round the bobbin.
2. Tilt bobbin presser (1) permitting the thread winder pulley to touch the running belt.
3. Adjust screw (2) to wind a bobbin about 80% of its capacity; turn the adjusting screw clockwise to increase or counterclockwise to reduce the amount of thread to be wound.
4. If the bobbin is wound unevenly, move tension bracket (3) or (4) to the left or the right so that the bobbin is wound evenly.
5. When the bobbin is filled up, the bobbin presser automatically releases the thread winder pulley from the running belt.

38. TROUBLES AND CORRECTIVE MEASURES

TROUBLES	CAUSES	CORRECTIVE MEASURES
<p>1 Thread breakage (Thread is untwisted or scraped)</p> <p>(Needle thread 20 to 30 mm (approx. 1") is left on the wrong side of the fabric.)</p>	<ol style="list-style-type: none"> ① There is a sharp edges or burrs on the thread path, needle point, hook blade point or bobbin case resting groove on the throat plate. ② Needle thread tension is too high. ③ Bobbin case opening lever provides an excessive clearance at the bobbin case. ④ Hook blade point hits the needle. ⑤ Hook is not lubricated properly. ⑥ Needle thread tension is too low ⑦ Thread take-up spring is too tight and its stroke is too small. ⑧ Needle-to-hook relation is wrong. ⑨ The thread twist is moved. 	<ul style="list-style-type: none"> ○ Remove sharp edges or burrs using a fine sandpaper. Polish the surface of the bobbin case resting groove on the throat plate using a buffing wheel. ○ Adjust the needle thread tension. ○ See 25 and adjust the clearance. ○ Adjust the needle-to-hook relation according to 23. ○ Increase the amount oil supplied to the hook according to 2. ○ Adjust the needle thread tension. ○ Reduce the tension of the spring and increase the stroke. ○ Adjust the needle-to-hook relation according to 23. ○ It is wound onto the needle.
<p>2 Stitch skipping</p>	<ol style="list-style-type: none"> ① Clearance between the needle and the hook blade point is too great. ② Needle-to-hook relation is wrong. ③ Pressing force of the presser foot is not enough. ④ Needle bar height is wrong. ⑤ Hook needle guard is not functional. ⑥ Needles are a little too thin. ⑦ The thread twist is moved. 	<ul style="list-style-type: none"> ○ Adjust the needle-to-hook relation according to 23. ○ Adjust the needle-to-hook relation according to 23. ○ Tighten the presser spring regulator. ○ Adjust the needle-to-hook relation according to 23. ○ Adjust the position of the hook needle guard according to 24. ○ Replace the needles by thicker ones. ○ It is wound onto the needle.
<p>3 Loose stitch.</p>	<ol style="list-style-type: none"> ① Bobbin thread does not pass through the forked end of the tension spring on the bobbin case. ② Thread path has rough surface. ③ Bobbin does not spin smoothly. ④ Bobbin case opening lever provides too much clearance at the bobbin. ⑤ Bobbin thread tension is too low. ⑥ Bobbin thread is wound too tightly. 	<p>Thread the bobbin case correctly.</p> <ul style="list-style-type: none"> ○ Remove rough surface using a fine sandpaper or polish the surface using a buffing wheel. ○ Replace the bobbin or the hook. ○ Adjust the bobbin case opening lever according to 25. ○ Adjust the bobbin thread tension. ○ Adjust the tension components on the thread winder.
<p>4 Thread escapes from the needle eye after thread trimming action.</p>	<ol style="list-style-type: none"> ① Thread tension given by the tension post No. 1 is too high. ② Timing of the thread trimming action is too early. ③ The needle thread is caught by the bobbin thread catching groove on the moving knife. 	<ul style="list-style-type: none"> ○ Loosen tension post No. 1 slightly. ○ Adjust the thread trimmer cam according to 27. ○ Adjust the initial position of the moving knife according to 28.
<p>5 Thread escapes from the needle eye at the start of stitching.</p>	<ol style="list-style-type: none"> ① Thread tension given by the tension post No. 1 is too high. ② Pressure of the clamp spring is too low. ③ Position of the clamp spring is wrong. ④ Needle hole in the presser foot is too large compared to the stitch length. ⑤ Bobbin thread tension is too low. ⑥ The needle thread is caught by the bobbin thread catching groove on the moving knife. 	<ul style="list-style-type: none"> ○ Loosen the tension post No. 1 slightly. ○ Adjust the clamp spring pressure or replace it. ○ Adjust the position of the clamp spring according to 30. ○ Replace the presser foot having a smaller needle hole. ○ Increase the bobbin thread tension. ○ Adjust the initial position of the moving knife according to 28.
<p>6 Thread is not cut sharply.</p>	<ol style="list-style-type: none"> ① Position of the moving knife to the fixed knife is wrong. ② Thread trimmer knife is chipped or worn. ③ Moving knife tilts wrongly. 	<ul style="list-style-type: none"> ○ Adjust the position of the moving knife and clamp spring according to 28, 29 and 30. ○ Resharpener or replace the knife blade. ○ Adjust the moving knife according to 29.
<p>7 Thread is not cut at all.</p>	<ol style="list-style-type: none"> ① Initial position of the moving knife is wrong. ② Moving knife does not come back to the blade of the fixed knife. ③ Timing of the thread trimming action is wrong. 	<ul style="list-style-type: none"> ○ Adjust the initial position of the moving knife according to 28. ○ Adjust the thread trimmer cam according to 27. ○ Adjust the thread trimmer cam according to 27.
<p>8 Needle thread shows on the wrong side of the fabric when sewing a corner.</p>	<ol style="list-style-type: none"> ① Thread tension release components start working a little early when the knee lifter is operated. 	<ul style="list-style-type: none"> ○ Adjust the timing of the thread tension release action according to 22.

39. AUTOMATIC PRESSER FOOT LIFTER, AK-11 (optional attachment)

The automatic presser foot lifter AK-11 is an optional attachment which is capable of lifting the presser foot and holding it at the highest position for 10 to 15 seconds after thread trimming has been made. A special motor is used for this lifter AK-11.

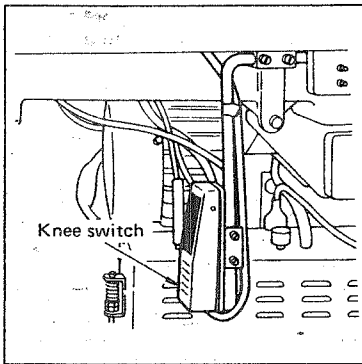

★ Operation

If you want to raise the presser foot during a sewing work, press the knee switch. Such raised presser foot will be coming down immediately after the knee switch is released.

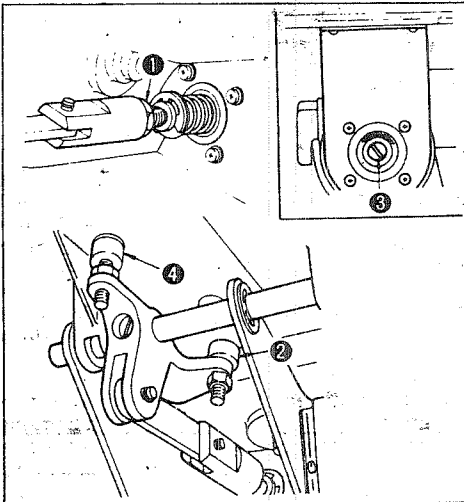

★ Presser foot lifter stroke

1. Loosen lock nut ① of the coupler.
2. Lower presser foot stopper (A) ② fully by loosening the lock nut.
3. Push the knee switch to drive the solenoid.
4. You can adjust the stroke of the presser foot by rotating plunger ③ on the far side of the solenoid; the stroke is increased by a clockwise turn and is decreased by a counterclockwise turn. (The maximum stroke performed by the presser foot is about 8 mm (5/16")).
5. Raise stopper (A) until it hits the oil reservoir by activating the solenoid.
6. Raise the stopper (A) by rotating it another half turn after releasing the knee switch.
7. Tighten the lock nuts of the stopper (A) and the coupler respectively.
8. Loosen the nut of stopper (B) ④, push the presser lifter lever towards the solenoid with your hand and adjust the height of the stopper (B) so that the clearance between the top end of the knee lifter rod and the knee lifter connecting rod located on the machine head become about 1 mm (3/64"). After obtaining a proper position, retighten each lock nut.

40. MOTOR PULLEY AND V-BELT

1. The standard motor to drive this machine is a MA-22(LH) Electro-motor.
2. Use a M-type B-belt.
3. Relation of the motor pulley to the belt length.

Outer diameter of the motor pulley	Part No. of motor pulley	Revolution		Belt length	Part No. of belt
		50Hz	60Hz		
105mm	MTS-P01000A0	4,250s.p.m.		43"	MTJ-VM004300
100	MTS-P00950A0	4,000			
95	MTS-P00900A0	3,820	4,540s.p.m.		
90	MTS-P00850A0	3,610	4,320		
85	MTS-P00800A0	3,390	4,000	42"	MTJ-VM004200
80	MTS-P00750A0	3,160	3,790		
75	MTS-P00700A0	2,950	3,520	41"	MTJ-VM004100
70	MTS-P00650A0	2,740	3,280		
65	MTS-P00600A0	2,530	3,030		
60	MTS-P00550A0	2,320	2,780	40"	MTJ-VM004000

4. The rate of revolution of the MA-22 Electromotor is continuously variable using the variable resistor in the motor control box. See the separate Instruction Book attached to the motor for details.

(CAUTION) Note that you can't use a commercially available pulley for this machine because of the tapered hole. When the machine is driven by HITACH single-phase motor, use a belt 1" longer than the above.

(How to install)

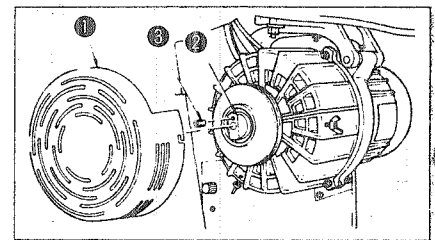

Remove pulley cover ①, fit the motor shaft key into the pulley key groove, tighten pulley nut ②, and then pulley nut screw ③. To remove the pulley, first remove the pulley cover, and perform the procedures in the reverse sequence to that of mounting.

(Please do not hesitate to contact our distributors or agents in your area for further informations when necessary.)

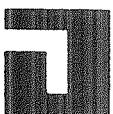

TOKYO JUKI INDUSTRIAL CO., LTD.

Head Office & Plant: 2-1, 8-chome, Kokuryo-cho, Chofu-shi, Tokyo, Japan
 Business Office: 23-3, Kabuki-cho 1-chome, Shinjuku-ku, Tokyo 160, Japan
 Cable: JUKI TOKYO Telex: 22967; 232-2301