

MODEL : AMS-210D

List No : 1159-07

PARTS LIST

Published:02/15/2019

CONTENTS

FRAME & MISCELLANEOUS COVER COMPONENTS (1)	1
FRAME & MISCELLANEOUS COVER COMPONENTS (2)	7
MAIM SHAFT & NEEDLE BAR COMPONENTS	9
PRESSER PLATE & MANUAL PRESSER MECHANISM COMPONENTS	13
PRESSER MECHANISM COMPONENTS	17
SHUTTLE DRIVER SHAFT COMPONENTS.....	21
WIPER MECHANISM COMPONENTS	25
TENSION RELEASE & THREAD TENSION COMPONENTS.....	27
TENSION RELEASE & THREAD TRIMMER MECHANISM COMPONENTS.....	29
X-Y COMPONENTS (1)	33
X-Y COMPONENTS (2)	37
CLOTH FEED MECHANISM COMPONENTS(FOR 210DSS,210DHS).....	39
CLOTH FEED MECHANISM COMPONENTS(FOR 210DSL,210DHL)	41
PNEUMATIC COMPONENTS(FOR 210DSL,210DHL).....	43
LUBRICATION COMPONENTS	45
TABLE COMPONENTS	47
THREAD STAND COMPONENTS.....	49
OPERATION BOX COMPONENTS	51
CONTROL BOX COMPONENTS	53
WIRING DIAGRAM	57
PEDAL & ELECTRICAL EQUIPMENT ACCESSORIE PART COMPONENTS	59
ACCESSORIE PART COMPONENTS	61
OPTIONAL PART COMPONENTS.....	63
ASM-210D PERFECT STITCH EXCLUSIVE PART COMPONENTS.....	67
LIST FOR INFORMATION OF CHANGE.....	71
HOW TO MAKE USE OF THIS PARTS LIST	72

FRAME & MISCELLANEOUS COVER COMPONENTS (1)

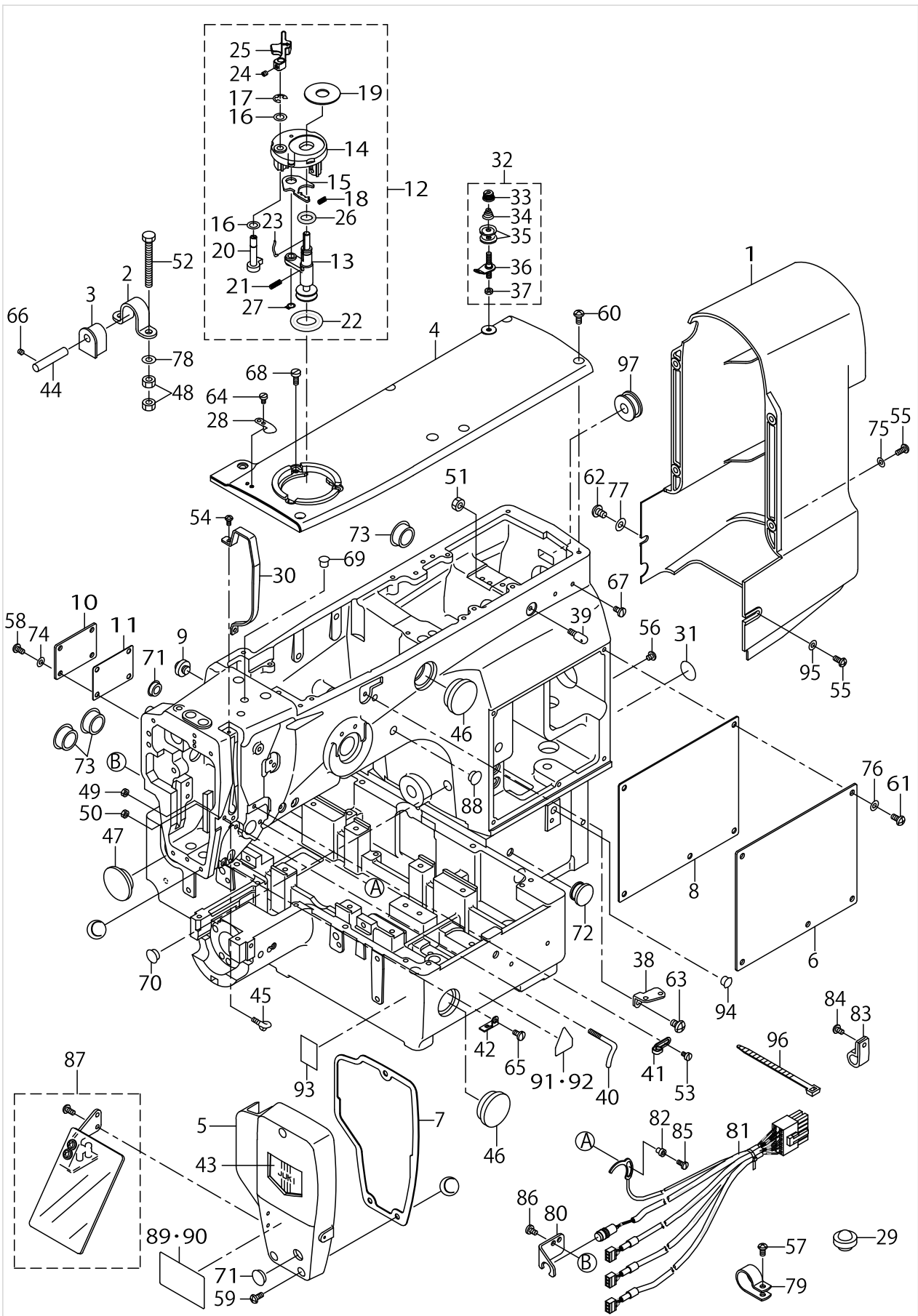

FRAME & MISCELLANEOUS COVER COMPONENTS (1)

No.	Parts No.	Parts name	Remarks	Level	Cons	Qty
1	B1107210D00	MOTOR COVER				1
2	B1111210D00	BED HINGE				2
3	B1115210D00	HINGE RUBBER				2
4	B1104210D00	TOP COVER				1
5	B1105210D00	FACE PLATE				1
6	B1121210D00	SIDE COVER				1
7	B1117210D00	FACE PLATE GASKET				1
8	B1122210D00	SIDE PLATE GASKET				1
9	B1116210D00	FRAME SUPPORT RUBBER				1
10	B1123210D00	COVER				1
11	B1125210D00	COVER GASKET				1
12	B3204210DB0	BOBBIN WINDER ASM.				1
13	B3204210DA0	BOBBIN WINDER SHAFT COMPL.		*		1
14	22537658	BOBBIN FITTING BASIS COMPL.		*		1
15	22538409	ADJUSTING PLATE		*		1
16	10618304	VERTICAL ROLLER WASHER		*		2
17	RE0500000K0	E-RING		*		1
18	B152989000CA	PRESSUR FOOT SPRING		*		1
19	B3205210000	CUSHION		*		1
20	22538151	BOBBIN CAM SHAFT COMPL.		*		1
21	B1148555000	SPRING		*		1
22	A321600100A	RUBBER RING		*		1
23	B3212761000	LATCH SPRING		*		1
24	SS8110422TP	SCREW 11/64-40 L=4		*		1
25	22538300	BOBBIN LEVER		*		1
26	RO092270200	RUBBER RING		*		1
27	RC0560711KP	RETAINING RING		*		1
28	10502300	THREAD CUTTER				1
29	11047107	RUBBER CUSHION				3
30	26211607	BALANCE COVER				1
31	10004109	GROUND MARK				1
32	14113468	BOBBIN THREAD TENSION ASM.				1
33	11072402	THREAD TENSION NUT		*		1
34	D7133555B00	CONNECTING ROD SPRING		*		1
35	B3126012000	THREAD TENSION DISK		*		2
36	14113450	BOBBIN THREAD TENSION ROD ASM.		*		1
37	NS6110310SP	NUT 11/64-40		*		1
38	B1111232000	THREAD GUIDE PLATE				1
39	B1123280000	FIRST THREAD GUIDE				1
40	B1125215P00	L-SHAPED THREAD GUIDE				1
41	22920508	ARM THREAD GUIDE A				1
42	B1129210000	FRAME THREAD GUIDE (B)				1
43	B1178191000	FACE PLATE DRESSING TABLE				1
44	B2707761000	HINGE STUD				2
45	B3114771000	THREAD GUIDE				1
46	B3501210000	OIL GAUGE				2
47	B8267180000	RUBBER PLUG				1

FRAME & MISCELLANEOUS COVER COMPONENTS (1)

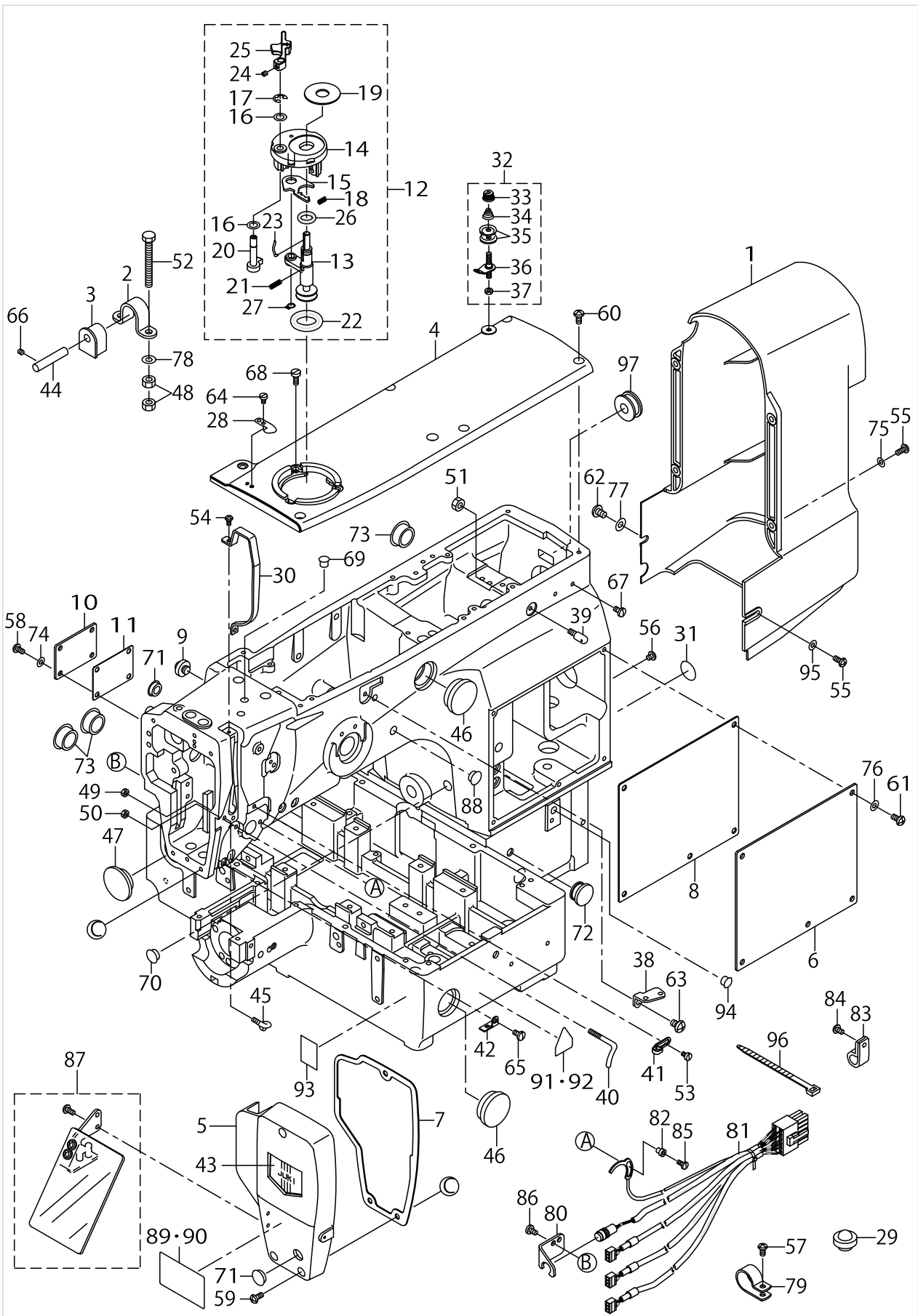

FRAME & MISCELLANEOUS COVER COMPONENTS (1)

No.	Parts No.	Parts name	Remarks	Level	Cons	Qty
48	NM6060001SC	NUT M6				8
49	NS6090310SP	NUT 9/64-40				1
50	NS6090310SP	NUT 9/64-40				1
51	NS6150310SP	NUT 15/64-28				1
52	SM9065513SF	SCREW M6X55				4
53	SS6090630TP	SCREW 9/64-40 L=6				1
54	SS4090715SP	SCREW 9/64-40 L=7				2
55	SS4111015SP	SCREW 11/64-40 L=10				5
56	SS4110515SP	SCREW 11/64-40 L=5				1
57	SS4110915SP	SCREW 11/64-40 L=9				1
58	SS4110815SP	SCREW 11/64-40 L=8				3
59	SS4111015SP	SCREW 11/64-40 L=10				3
60	SS4121015SP	SCREW 3/16-28 L=10				6
61	SS4121015SP	SCREW 3/16-28 L=10				5
62	SS4150915SP	SCREW 15/64-28 L=9				1
63	SS4150915SP	SCREW 15/64-28 L=9				1
64	SS6090620SP	SCREW 9/64-40 L=6				1
65	SS7110840SP	SCREW 11/64-40 L=7.8				1
66	SS8110422TP	SCREW 11/64-40 L=4				2
67	SS7110840SP	SCREW 11/64-40 L=7.8				2
68	SS6111140SP	SCREW 11/64-40 L=11				3
69	TA0750704R0	RUBBER PLUG				1
70	TA1050504R0	RUBBER PLUG				1
71	TA1250406R0	RUBBER PLUG D=12.5 L=4				2
72	TA1850805R0	PLUG				1
73	TA2100904R0	RUBBER PLUG				3
74	WP0450000SD	WASHER 4.5X8X0.5				3
75	WP0450000SD	WASHER 4.5X8X0.5				4
76	WP0501016SD	WASHER 5X10.5X1				5
77	WP0621016SD	WASHER 6.2X13X1				1
78	WP0621016SD	WASHER 6.2X13X1				4
79	HX00150000K	CABLE CLIP				1
80	B4110210D00A	STOP SWITCH INSTALLING PLATE				1
81	40022507	SENSOR CABLE ASM.				1
82	B2703210000	BUSHING				1
83	HX00123000A	CABLE CLIP				3
84	SS4110715SP	SCREW 11/64-40 L=7				3
85	SS7090850SP	SCREW 9/64-40 L=8				1
86	SS7110710SP	SCREW 11/64-40 L=7				2
87	13551254	SAFETY PLATE ASM.				1
88	TA1050504R0	RUBBER PLUG	FOR 210DSL,DHL			2
89	CM300200301	SAFETY LABEL, 5(SMALL).	FOR USE IN JAPAN			1
90	CM3002003A1	SAFETY LABEL.,6 (SMALL).	FOR EXPORT			1
91	CM3002000B2	LABEL(25).	FOR USE IN JAPAN			1
92	CM300200002	CAUTION LABEL(25)				1
93	B1143210000	LABEL				1
94	TA0850604R0	RUBBER PLUG	FOR 210DSL,DHL			1

FRAME & MISCELLANEOUS COVER COMPONENTS (1)

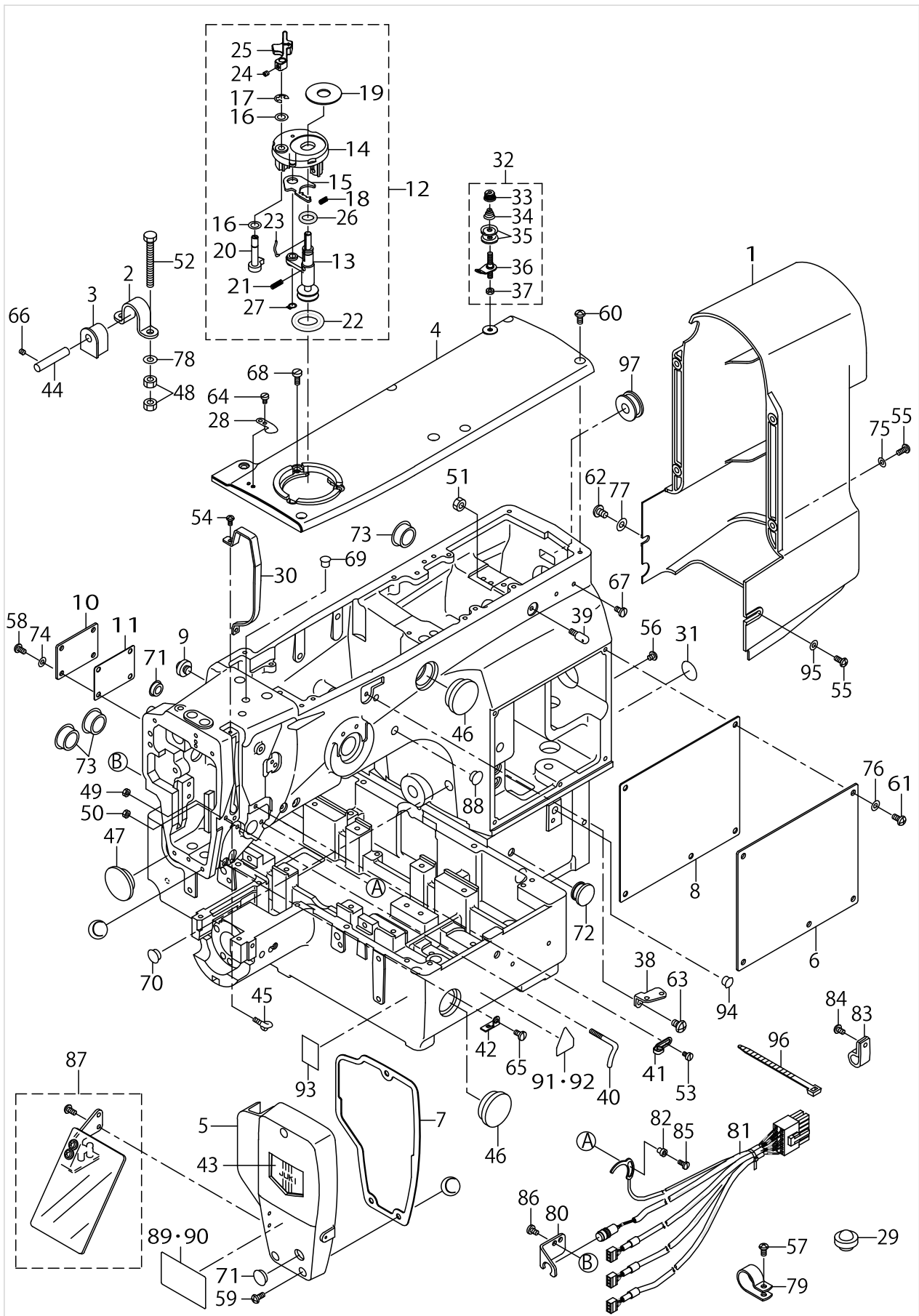

FRAME & MISCELLANEOUS COVER COMPONENTS (1)

No.	Parts No.	Parts name	Remarks	Level	Cons	Qty
95	WP0450801SD	WASHER 4.5X10X0.8				1
96	EA9500B0100	CABLE BAND				3
97	B1126210000	WIRE BUSHING				1

FRAME & MISCELLANEOUS COVER COMPONENTS (2)

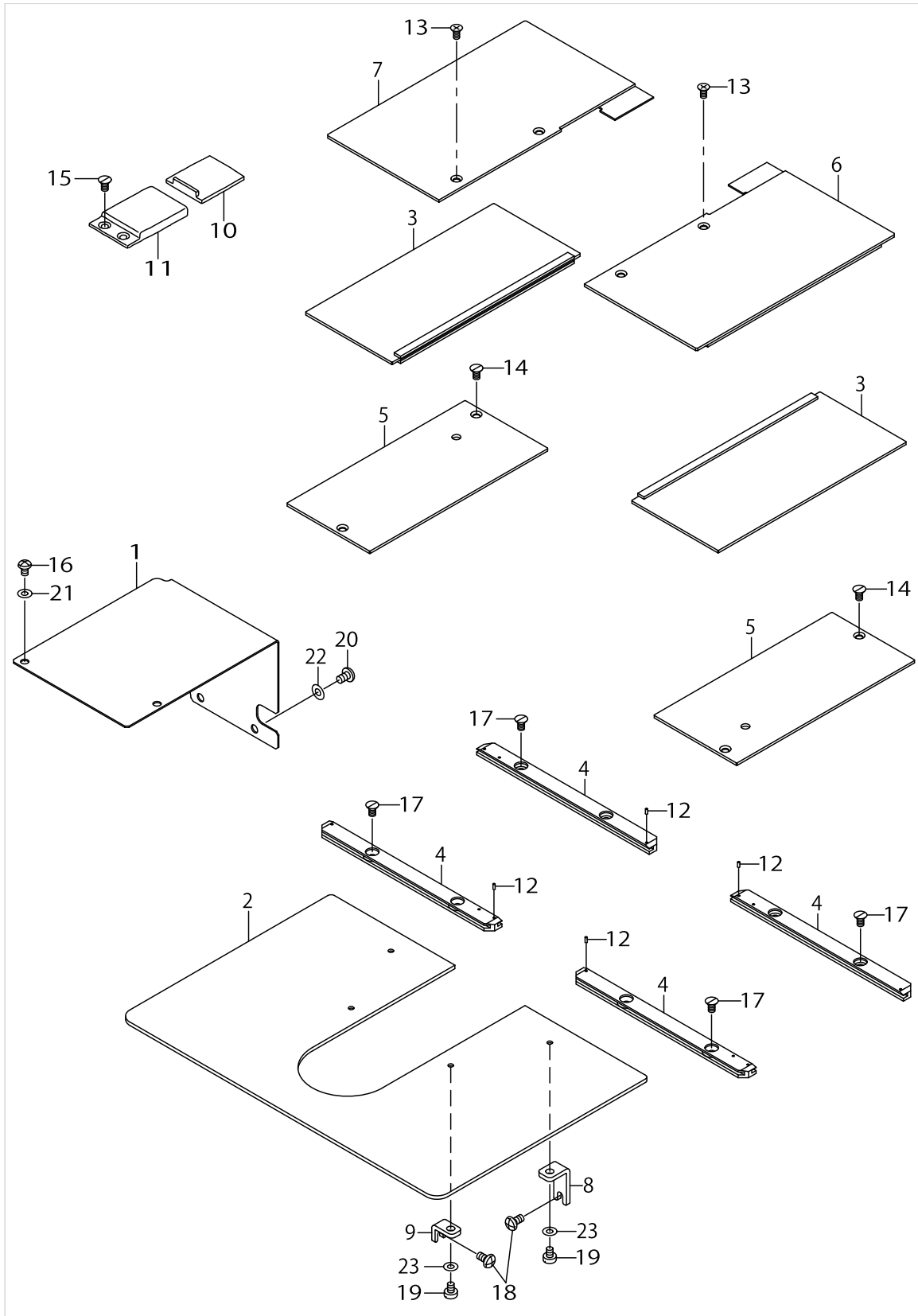

FRAME & MISCELLANEOUS COVER COMPONENTS (2)

No.	Parts No.	Parts name	Remarks	Level	Cons	Qty
1	B1106210D00	X MOTOR COVER				1
2	B1112210D00	NEEDLE PLATE SUPPORT COVER				1
3	B1109210DA0	X MOVEMENT LOWER COVER ASM.				2
4	B1181210D00	X MOVEMENT COVER RAIL				4
5	B1108210D00	FEED BASE COVER				2
6	B1110210DA0	X MOVEMENT UPPER COVER ASM.,R				1
7	B1118210DA0	X MOVEMENT UPPER COVER ASM.,L				1
8	B1113210D00	COVER SUPPORT				2
9	B1113223C00	COVER SUPPORTER				2
10	B1123210000	Y DRIVE COVER				1
11	B1124210000	Y FIXED COVER				1
12	PS0150042K0	SPRING PIN 1.5X 4				4
13	SM1040801SC	SCREW M4X0.7 L=8				4
14	SS1110840SP	SCREW 11/64-40 L=8				4
15	SS1110840SP	SCREW 11/64-40 L=8				2
16	SS4110715SP	SCREW 11/64-40 L=7				2
17	SS1110840SP	SCREW 11/64-40 L=8				8
18	SS4120915SP	SCREW 3/16-28 L=9				4
19	SS6110610TP	SCREW 11/64-40 L=6				4
20	SM4050855SP	SCREW				2
21	WP0450801SD	WASHER 4.5X10X0.8				2
22	WP0531000SD	WASHER M5				2
23	WP0520656SA	WASHER 5.2X9.5X0.6				4

MAIM SHAFT & NEEDLE BAR COMPONENTS

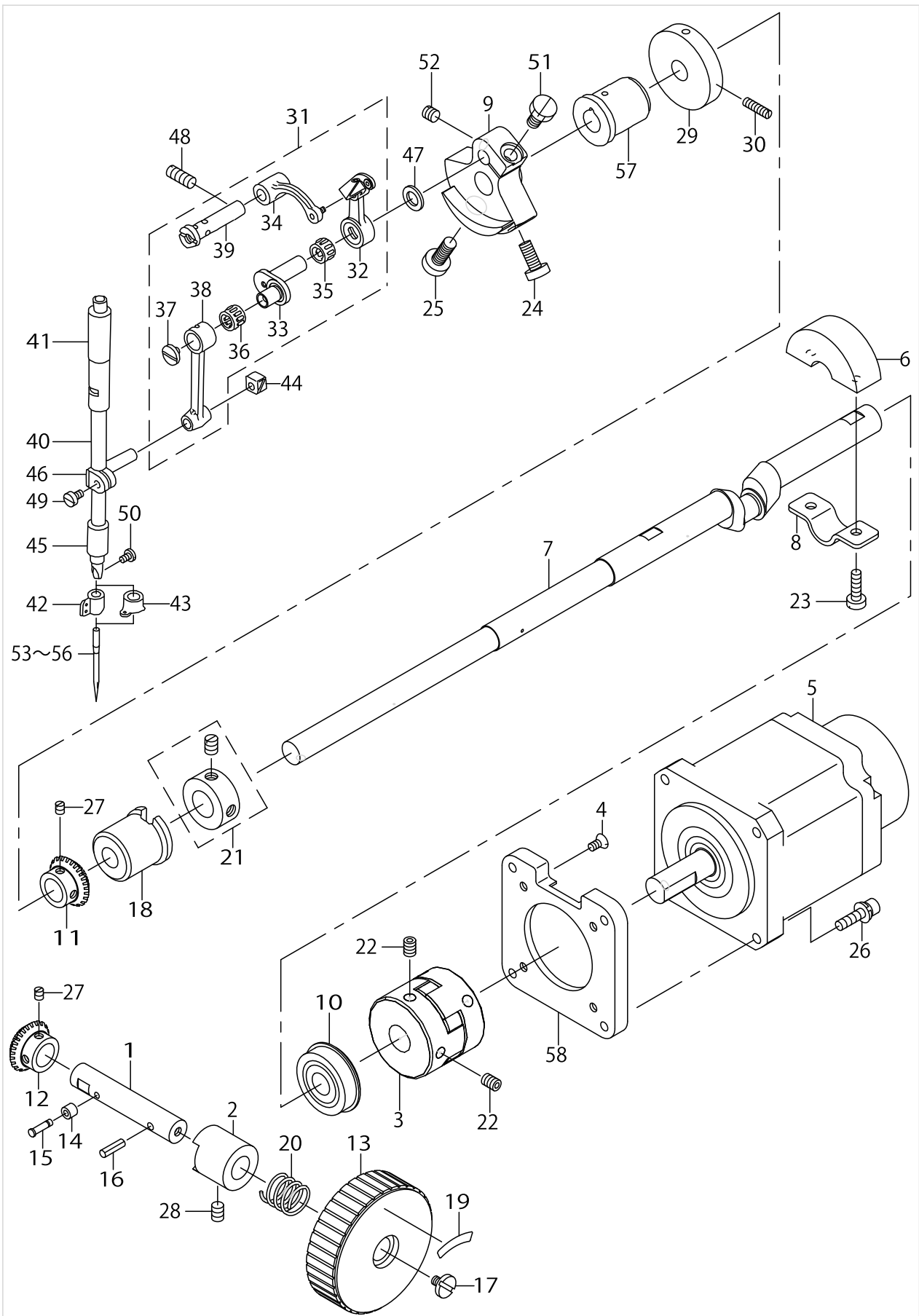

MAIM SHAFT & NEEDLE BAR COMPONENTS

No.	Parts No.	Parts name	Remarks	Level	Cons	Qty
1	B1213210D00	PULLEY SHAFT				1
2	B1214210D00	PULLEY BUSHING				1
3	23604309	COUPLING				1
4	SS1110840SP	SCREW 11/64-40 L=8				4
5	40022517	AC SERVO MOTOR				1
6	B1207210D00	CRANK BALANCER				1
7	B1201210D00	MAIN SHAFT				1
8	B1208210D00	CRANK BALANCER FIX PLATE				1
9	B1206210D00	COUNTER WEIGHT				1
10	G1216870000	UPPER SHAFT REAR BEARING				1
11	B1215210D00	PULLEY GEAR,A				1
12	B1216210D00	PULLEY GEAR,B				1
13	B1212210D00	PULLEY				1
14	11217213	ROLLER				1
15	11217114	ROLLER SHAFT				1
16	PS0400142KH	SPRING PIN 4X14				1
17	A1230500000A	HANDWHEEL SETSCREW				1
18	B1203210000	BUSHING, INTERMEDIATE				1
19	B1144210000	REVOLVING DIRECTION LABEL				1
20	GAF01007000	SPRING				1
21	CS147121ESH	THRUST COLLAR ASM.D=14.72 W=12				1
22	SM8060812TP	SCREW M6 L=8				4
23	SS6121610SP	SCREW 3/16-28 L=15.5				2
24	SS6151412TP	SCREW 15/64-28 L=14				1
25	SS6681712TP	SCREW 9/32-28 L=16.5				1
26	SL6052092TN	SCREW				4
27	SS8110510SP	SCREW 11/64-40 L=5				4
28	SS8150822TP	SCREW 15/64-28 L=8				1
29	B3213205000	BOBBIN WINDER DRIVING WHEEL				1
30	SS8111610SP	SCREW 11/64-40 L=15.5				2
31	B1901210DC0	LINK THREAD TAKE-UP				1
32	B1901210DA0	THREAD TAKE-UP LEVER COMPL.		*		1
33	B1407210D00	NEEDLE BAR CRANK		*		1
34	B1903210000	THREAD TAKE-UP CRANK		*		1
35	B1905541000	NEEDLE BUSHING		*		1
36	B1411804000	NEEDLE DRIVING LEVER BEARING		*		1
37	B1903552000	LEFT SCREW		*		1
38	B1404280000	NEEDLE BAR CRANK ROD		*		1
39	B1904280000	BALANCE CRANK PIN		*		1
40	B1401210A00	NEEDLE BAR				1
41	B1402280000	NEEDLE ROD METAL				1
42	B1405210000	THREAD GUIDE A	FOR 210DSS,DSL			1
43	B1406210000	THREAD GUIDE	FOR 210DHS,DHL			1
44	B1414232000	SQUARE BLOCK				1
45	B1403280000	NEEDLE ROD LOWER METAL				1
46	B14115520A0	NEEDLE BAR CONNECTING ASM.				1
47	B1223771000	NEEDLE ROD CRANK WASHER				1

MAIM SHAFT & NEEDLE BAR COMPONENTS

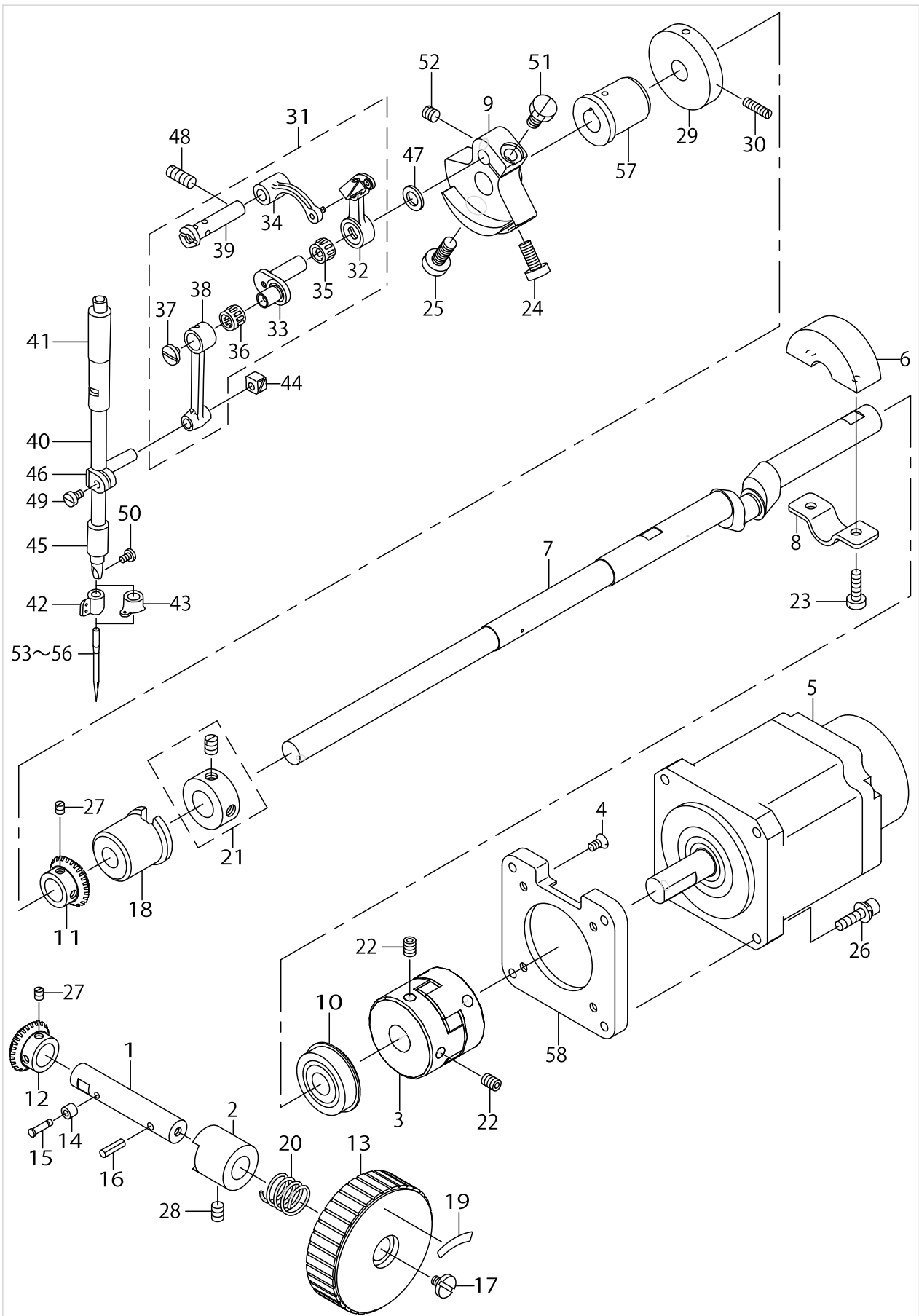

MAIM SHAFT & NEEDLE BAR COMPONENTS

No.	Parts No.	Parts name	Remarks	Level	Cons	Qty
48	SS8151550SP	SCREW 15/64-28 L=15				1
49	SS6090670TP	SCREW 9/64-40 L=6				1
50	SS7080510TP	SCREW 1/8-44 L=4.5				1
51	SS9661230CP	SCREW 1/4-40 L=12				1
52	SS8660610TP	SCREW 1/4-40 L=6				1
53	MDP500B1400	NEEDLE DPX5 #14	FOR 210DSS,DSL			1
54	MDP170B1800	NEEDLE DPX17 #18	FOR 210DHS,DHL			1
55	MC200501000	NEEDLE #100	FOR 210DSS,DSL			1
56	MC372001100	NEEDLE 135X17 #110	FOR 210DHS,DHL			1
57	B1202210000	BUSHING, FRONT				1
58	40022327	MOTOR FITTING PLATE				1

PRESSER PLATE & MANUAL PRESSER MECHANISM COMPONENTS

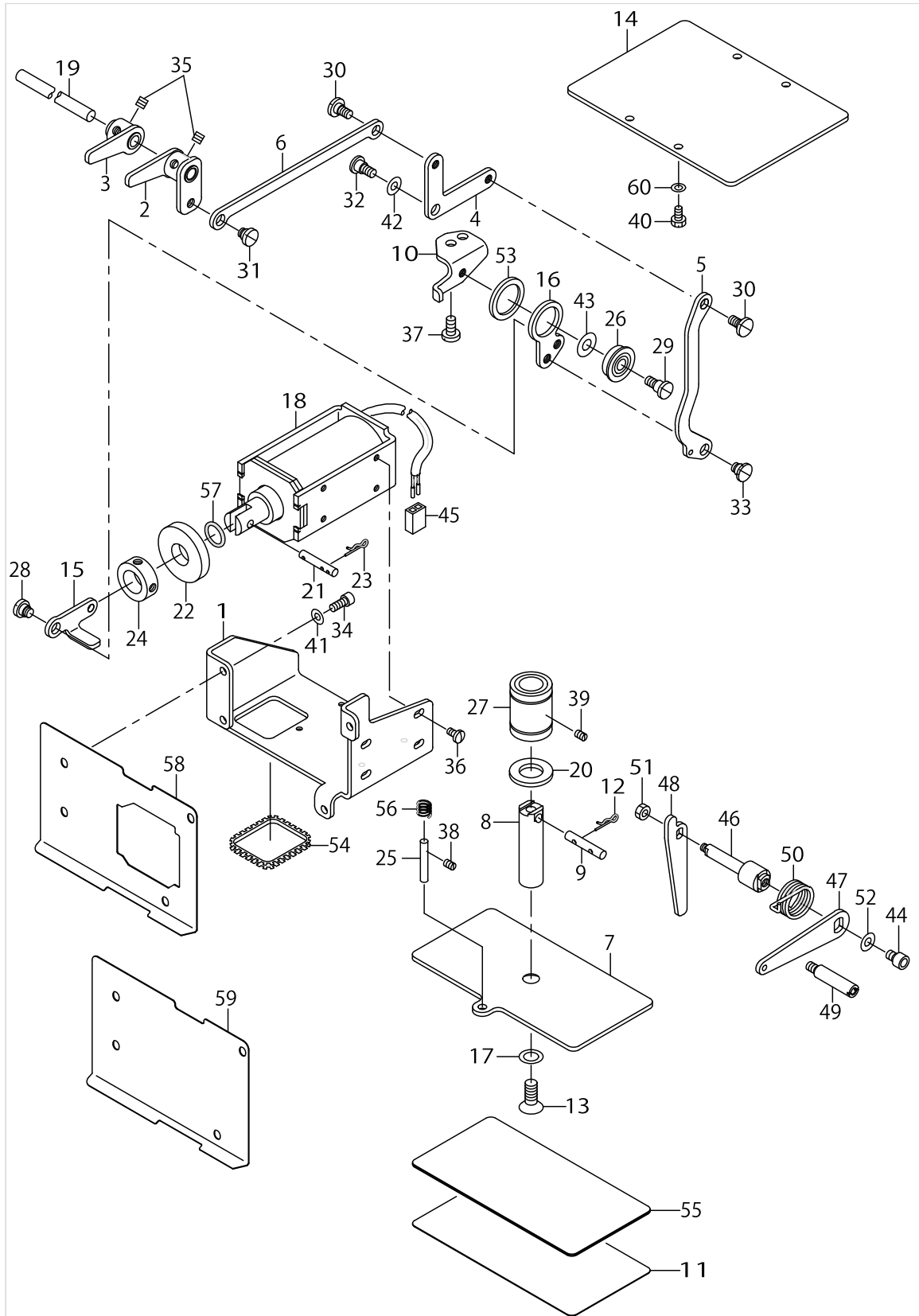

PRESSER PLATE & MANUAL PRESSER MECHANISM COMPONENTS

No.	Parts No.	Parts name	Remarks	Level	Cons	Qty
1	B1507210D00	MAGNET INSTALLING PLATE				1
2	B1501210DA0	ARM ASM.,A	FOR 210DSS,DHS			1
3	B1503210DA0	ARM ASM.,B	FOR 210DSS,DHS			1
4	B1504210D00	L-SHAPED LINK	FOR 210DSS,DHS			1
5	B1505210D00	CONNECTING PLATE	FOR 210DSS,DHS			1
6	B1506210D00	CONNECTING LINK	FOR 210DSS,DHS			1
7	B1502210D00	PRESSER PLATE	FOR 210DSS,DHS			1
8	B1525210D00	PRESSER SHAFT	FOR 210DSS,DHS			1
9	B1508210D00	PIN	FOR 210DSS,DHS			1
10	B1509210D00	LINK GUIDE PLATE	FOR 210DSS,DHS			1
11	B1520210D00A	PRESSER PLATE SHEET				1
12	B1515210D00	PIN	FOR 210DSS,DHS			2
13	B1516210D00	SCREW	FOR 210DSS,DHS			1
14	B1522210D00	PRESSER PLATE(PNEUMATIC TYPE)	FOR 210DSL,DHL			1
15	B1510210D00	MAGNET LINK	FOR 210DSS,DHS			1
16	B1511210D00	PRESSER LINK	FOR 210DSS,DHS			1
17	B1530210D00	PRESSER PLATE SHEET WASHER	FOR 210DSS,DHS			3
18	B1628210D0B	SOLENOID	FOR 210DSS,DHS			1
19	B1701210000	LOWERING SHAFT	FOR 210DSS,DHS			1
20	D3310555D00	RUBBER WASHER	FOR 210DSS,DHS			1
21	B1513210D00	MAGNET PIN	FOR 210DSS,DHS			1
22	D2468555B00	RUBBER PLUNGER	FOR 210DSS,DHS			1
23	B1515210D00	PIN	FOR 210DSS,DHS			2
24	CS1701011SZ	THRUST COLLAR D=17 W=10	FOR 210DSS,DHS			1
25	PH0500322C0	PIN 5X32	FOR 210DSS,DHS			1
26	SB108000500	RADIAL BEARING	FOR 210DSS,DHS			1
27	SB716000200	BEARING	FOR 210DSS,DHS			1
28	SD0800341SP	HINGE SCREW D=8 H=3.4	FOR 210DSS,DHS			1
29	SD0790601SP	HINGE SCREW D=7.94 H=6	FOR 210DSS,DHS			1
30	SD0720331SP	HINGE SCREW D= 7.24 H= 3.3	FOR 210DSS,DHS			2
31	SD0800341SP	HINGE SCREW D=8 H=3.4	FOR 210DSS,DHS			1
32	SD0790501SP	HINGE SCREW D=7.94 H=5	FOR 210DSS,DHS			1
33	SD0800422CP	HINGE SCREW D= 8 H= 4.2	FOR 210DSS,DHS			1
34	SM6051202TP	SCREW M5X0.8 L=12				4
35	SM8060612TP	SCREW M6 L=6	FOR 210DSS,DHS			4
36	SS7110840SP	SCREW 11/64-40 L=7.8	FOR 210DSS,DHS			4
37	SS7151210SP	SCREW 15/64-28 L=12	FOR 210DSS,DHS			2
38	SS8120740SP	SCREW 3/16-28 L=7	FOR 210DSS,DHS			1
39	SS8120740SP	SCREW 3/16-28 L=7	FOR 210DSS,DHS			1
40	SS9120910TP	SCREW 3/16-28 L=9	FOR 210DSL,DHL			4
41	WP0531001SC	WASHER				4
42	WP0850002SP	WASHER 8.5X18X1.6	FOR 210DSS,DHS			1
43	WP0621016SH	WASHER	FOR 210DSS,DHS			1
44	SM6060802TP	SCREW M6 L=8				1
45	HK03461002D	HOUSING	FOR 210DSS,DHS			1
46	B1701210D00	LOWERING LEVER SHAFT				1
47	B1702210D00	LOWERING LEVER				1

PRESSER PLATE & MANUAL PRESSER MECHANISM COMPONENTS

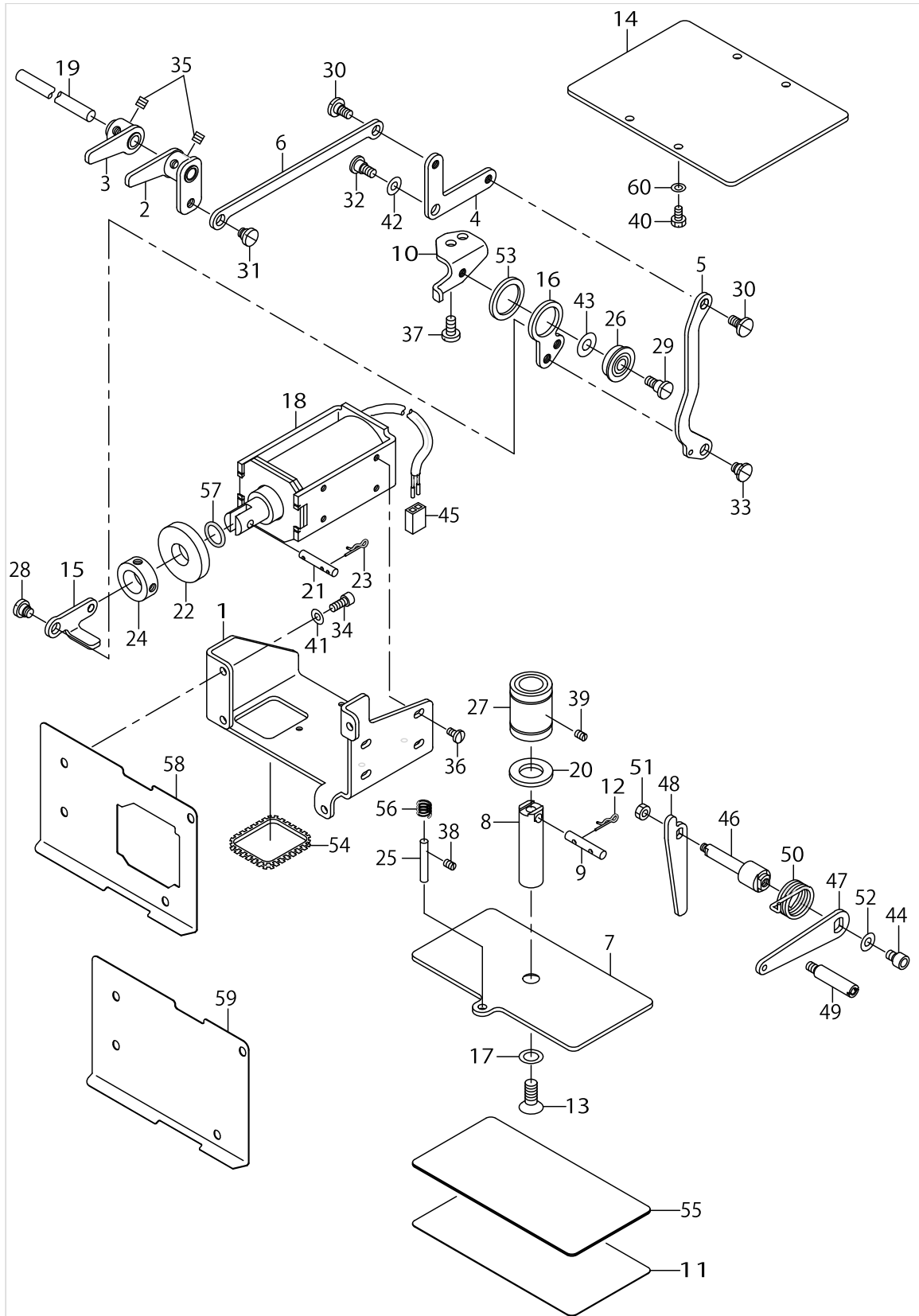

PRESSER PLATE & MANUAL PRESSER MECHANISM COMPONENTS

No.	Parts No.	Parts name	Remarks	Level	Cons	Qty
48	B1703210D00	LOWERING PLATE				1
49	22924005	PUMP BODY STRUT				1
50	B1526804000	SPRING				1
51	NM6050001SD	NUT M5X0.8				1
52	WP0641601SC	WASHER				1
53	WP2232916SZ	WASHER	FOR 210DSS,DHS			1
54	HX00223000A	BUSHING				1
55	B1531210D00	PRESSER PLATE FITTING SHEET				1
56	12210803	SPRING	FOR 210DSS,DHS			1
57	RO137230100	RUBBER RING	FOR 210DSS,DHS			1
58	B3511210D00A	BED OIL PREVENTION PLATE	FOR 210DSS,DHS			1
59	B3511210D0AA	BED OIL PREVENTION PLATE	FOR 210DSL,DHL			1
60	WP0520656SA	WASHER 5.2X9.5X0.6	FOR 210DSL,DHL			4

PRESSER MECHANISM COMPONENTS

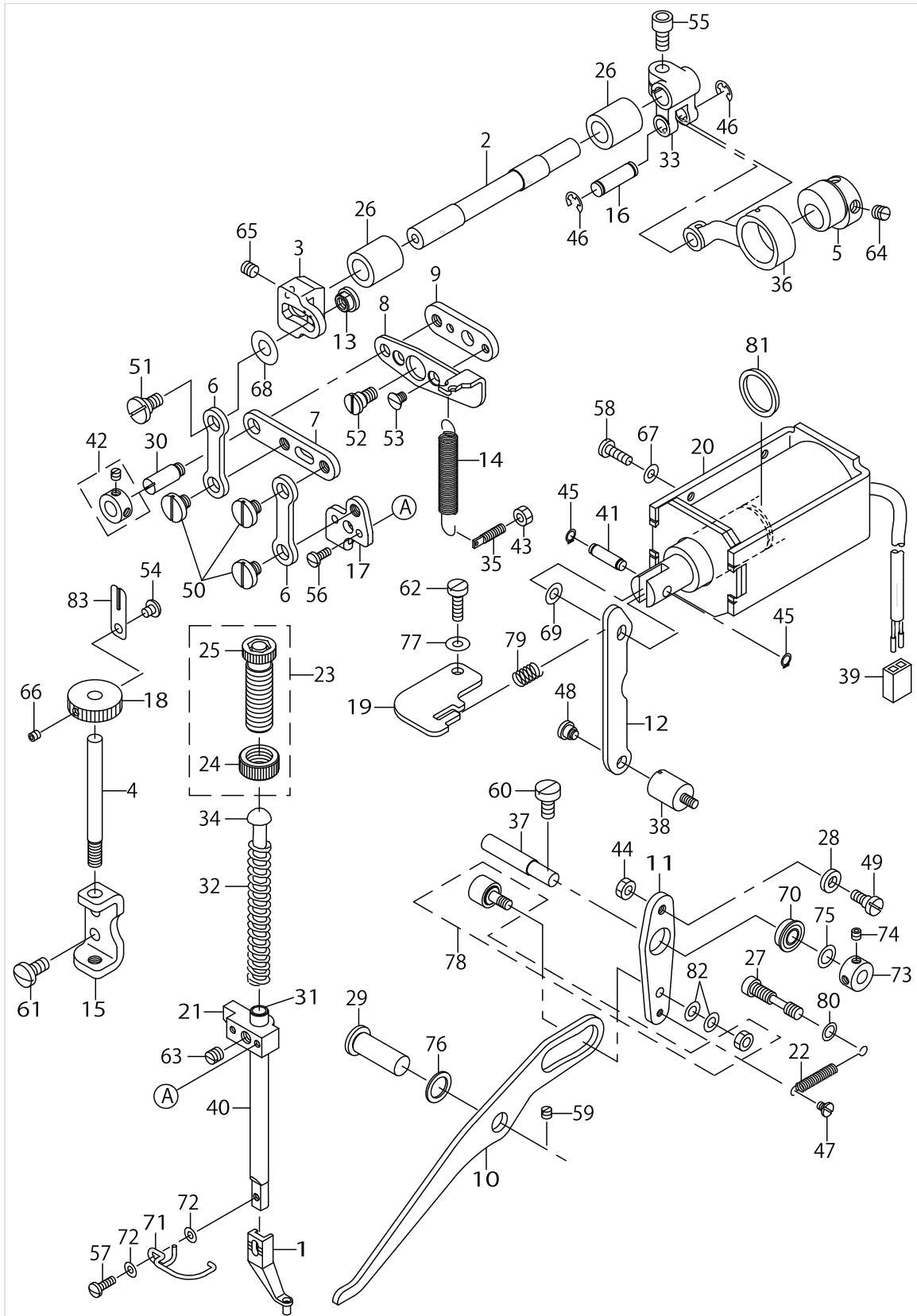

PRESSER MECHANISM COMPONENTS

No.	Parts No.	Parts name	Remarks	Level	Cons	Qty
1	B1601210D00A	INTERMEDIATE PRESSER A				1
2	B1604210D00	INTERMEDIATE PRESSER SHAFT				1
3	B1603210D00	ADJUSTING ARM				1
4	B1630210D00	ADJUSTING SHAFT				1
5	B1609210D00	ECCENTRIC CAM				1
6	B1612210D00	INTERMEDIATE PRESSER LINK,A				2
7	B1610210D00	INTERMEDIATE PRESSER LINK,B				1
8	B1606210D00	POSITIONING LINK A				1
9	B1607210D00	POSITIONING LINK B				1
10	B1620210D00	LIFTING LINK A				1
11	B1621210D00A	LIFTING LINK B				1
12	B1622210D00	LIFTING LINK C				1
13	B1633210D00	ADJUSTING NUT				1
14	B1642210D00	INTERMEDIATE PRESSER SPRING B				1
15	B1632210D00	ADJUSTING SHAFT BRACKET				1
16	B1627210D00	ROD CONNECTING SHAFT				1
17	B1611210D00	LINK CONNECTING PLATE				1
18	B1631210D00	HEIGHT ADJUSTING KNOB				1
19	B1629210D00A	INNERPRESSER MAGNET STOPPER				1
20	B1628210D0B	SOLENOID				1
21	22907208	PRESSER BAR GUIDE BRACKET				1
22	11010303	FEED REVERSE SPRING				1
23	22907554	PRESSER SPRING REG NUT ASM.				1
24	22907604	PRESSER SPRING REGULATOR NUT		*		1
25	22907505	PRESSER SPRING REGULATOR		*		1
26	11847308	BUSHING, REAR				1
27	B1614210D00	SPRING RACK				1
28	13722509	DRIVING SAFETY ROLLER				1
29	B1641562000	FEED REGULATING ARM SHAFT				1
30	B1408180000	HINGE SCREW				1
31	26502906	INNER PRESSER BAR				1
32	B161121000A	INNER PRESSER SPRING.				1
33	12284303	FORKED LINK				1
34	B1629224000	PRESSER GUIDE BAR				1
35	B1649161000	TENSION SPRING ADJUSTING SCREW				1
36	B2102816000A	CHAIN LOOPER ROD (22MM)				1
37	B1615210D00	LIFTING LINK B SHAFT				1
38	B8404352000	BELT COVER SUPPORT STUD				1
39	HK03461002E	CONNECTOR				1
40	D1510491D00	BUSHING, LOWER				1
41	B1626210D00	PIN				1
42	CS079073ASH	THRUST COLLAR ASM.				1
43	NS6110310SP	NUT 11/64-40				1
44	NS6620310SP	NUT 3/16-32				1
45	RC0470611KP	RETAINING RING 4.7				2
46	RE0500000K0	E-RING				2
47	SD0400191TP	HINGE SCREW D=4 H=1.9				1

PRESSER MECHANISM COMPONENTS

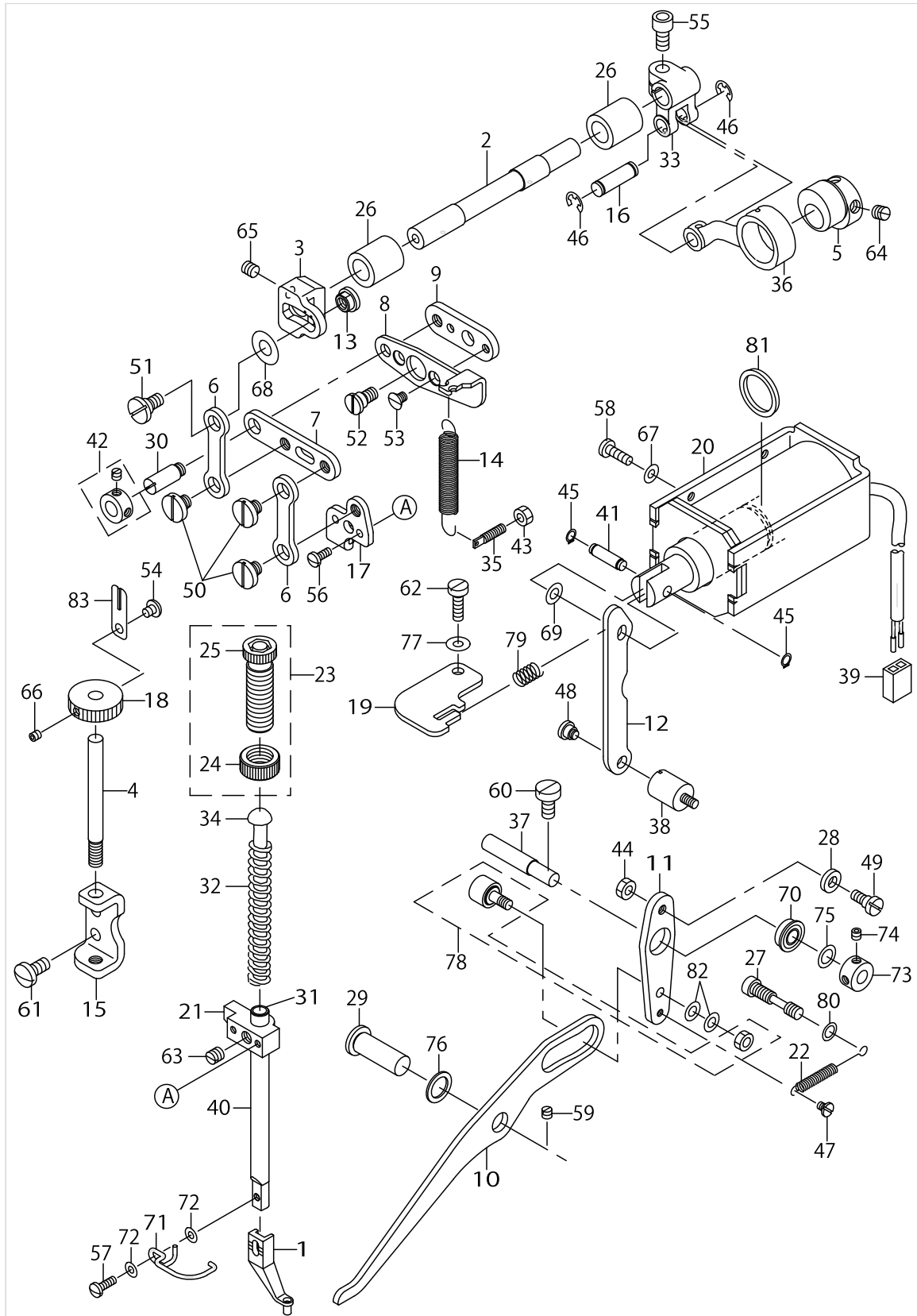

PRESSER MECHANISM COMPONENTS

No.	Parts No.	Parts name	Remarks	Level	Cons	Qty
48	SD0640321SP	HINGE SCREW D= 6.35 H= 3.2				1
49	SD0600402TP	HINGE SCREW D= 6 H= 4				1
50	SD0800331TH	HINGE SCREW D=8 H=3.25				3
51	SD0800402TP	HINGE SCREW D= 8 H= 4				1
52	B1605210D00	HINGE SCREW				1
53	SS1110640TP	SCREW 11/64-40 L= 5.5				2
54	SS6110610TP	SCREW 11/64-40 L=6				1
55	SM6061202TP	SCREW M6 L=12				1
56	SS7090910SP	SCREW 9/64-40 L= 8.5				2
57	SS7091110SP	SCREW 9/64-40 L=10.5				1
58	SS7111410SP	SCREW 11/64-40 L=14				2
59	SS8120410SP	SCREW 3/16-28 L=3.8				1
60	SS6151220SP	SCREW 15/64-28 L=11.5				1
61	SS7151210SP	SCREW 15/64-28 L=12				2
62	SS6121610SP	SCREW 3/16-28 L=15.5				1
63	SS8660610TP	SCREW 1/4-40 L=6				1
64	SS8660610TP	SCREW 1/4-40 L=6				2
65	SM8060602TP	SCREW M6X6				1
66	SM8040412TP	SET SCREW M4 L=4				1
67	WP0480856SP	WASHER 4.8X8.4X0.8				2
68	WP0611626SP	WASHER 15X6X1.6				1
69	WP0611626SP	WASHER 15X6X1.6				1
70	SB107000100	BEARING				1
71	B1634210D00	FINGER GUARD				1
72	WP0430800SC	WASHER M4				2
73	CS0700811SH	THRUST COLLAR D=7 W=8				1
74	SS8110422TP	SCREW 11/64-40 L=4				2
75	WP0740516SP	WASHER 7.4X11.8X0.5				1
76	26226001	WASHER				1
77	WP0482086SD	WASHER 4.8X11.5X2				1
78	B1619210D00	CAM FOLLOWER				1
79	B1673180000	SPRING				1
80	WP0621026SP	WASHER 6.2X9.5X1				1
81	B1652210D00	GASKET				1
82	WP0531000SD	WASHER M5				2
83	13717707	ROCKING ADJUSTING SCREW STOPPE				1

SHUTTLE DRIVER SHAFT COMPONENTS

No.	Parts No.	Parts name	Remarks	Level	Cons	Qty
1	B1836210D00	OSCILLATING ECCENTRIC SHAFT				1
2	B1805210D00	OSCILLATOR				1
3	CS1201010SH	THRUST COLLAR ASM. D=12 W=10				1
4	B1817210DAB	SHUTTLE RACE RING COMPL.,B				1
5	B1814210DA0	SHUTTLE ASM.				1
6	B1814210D00	SHUTTLE		*		1
7	B1820210D00	SHUTTLE OIL FELT,A		*		2
8	B1821210D00	SHUTTLE OIL FELT,B		*		1
9	B1813980000	SHUTTLE NEEDLE OUTER RING		*		1
10	26231100	SHUTTLE LUBRICATING PLATE		*		1
11	B3504280000	SHUTTLE FELT		*		1
12	SS4090415SP	SCREW 9/64-40 L=4		*		2
13	WP0952616SD	WASHER 9.5X14.8X2.6		*		1
14	CQ252200000	OIL WICK		*		1.3
15	BP300000000	VINYL PIPE		*		0.8
16	26501858	INNER HOOK PRESSER ASM.		*		2
17	B1822215P00	INNER HOOK PRESSER SPRING		*		2
18	RE0300000K0	E-RING 3		*		2
19	13529607	SHUTTLE PACKING		*		2
20	B1812210D00	SHUTTLE DRIVER				1
21	B1818210D0A	SHUTTLE	FOR 210DSS,DSL			1
22	B1818210D0B	SHUTTLE,H	FOR 210DHS,DHL			1
23	B1806210D00	BOBBIN				1
24	B1828210DAA	BOBBIN CASE ASM.				1
25	B1828210D0A	BOBBIN CASE		*		1
26	B1808210D00	SPRING		*		1
27	SS7110510SP	SCREW 11/64-40 L=5				1
28	SS7110840SP	SCREW 11/64-40 L=7.8				1
29	SS8150822TP	SCREW 15/64-28 L=8				2
30	SS7111110TP	SCREW 11/64-40 L=10.5				2
31	10523504	WASHER				1
32	B1802210D00	CRANK ROD				1
33	13508403	LOWER SHAFT REAR METAL				1
34	13508700	HOOK COVER PRESSER SPRING PIN				1
35	26221101	HOOK COVER PRESSER SPRING A				1
36	26221200	HOOK COVER PRESSER SPRING B				1
37	13816855	HOOK COVER ASM.				1
38	B1411804A00	BEARING (A)	SELECTIVE PARTS			2
39	B1411804B00	NEEDLE DRIVING LEVER BEARING B	SELECTIVE PARTS			2
40	B1411804C00	NEEDLE DRIVING LEVER BEARING C	SELECTIVE PARTS			2
41	B1411804D00	BEARING (D)	SELECTIVE PARTS			2
42	B1411804A00	BEARING (A)	SELECTIVE PARTS			1
43	B1411804B00	NEEDLE DRIVING LEVER BEARING B	SELECTIVE PARTS			1
44	B1411804C00	NEEDLE DRIVING LEVER BEARING C	SELECTIVE PARTS			1
45	B1411804D00	BEARING (D)	SELECTIVE PARTS			1
46	B1808980000	LOWER SHAFT THRUST WASHER				1
47	B1815980000	SHUTTLE UPPER SPRING	FOR 210DSS,DSL			1

SHUTTLE DRIVER SHAFT COMPONENTS

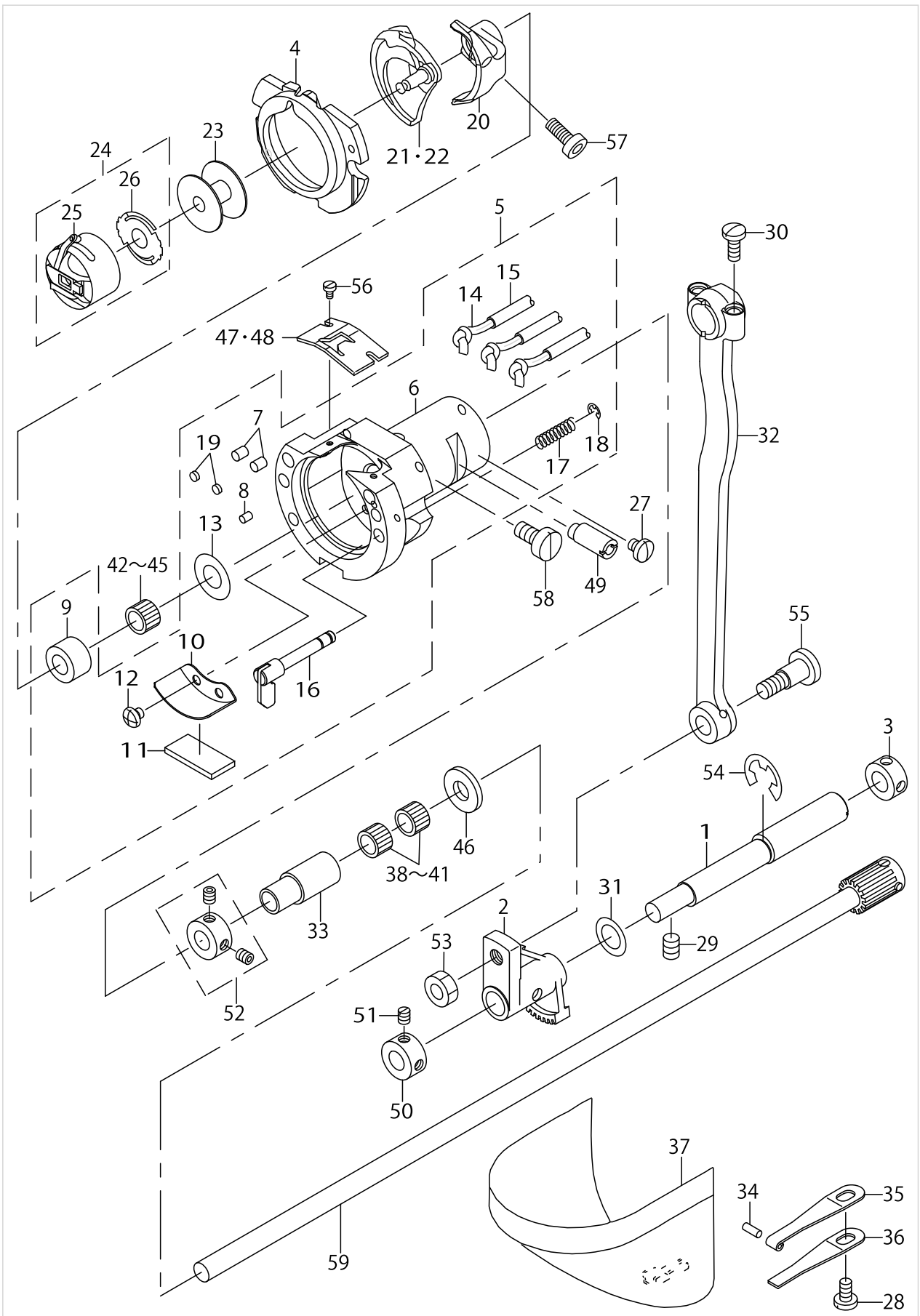

SHUTTLE DRIVER SHAFT COMPONENTS

No.	Parts No.	Parts name	Remarks	Level	Cons	Qty
48	B1815210000	INNER HOOK UPPER SPRING	FOR 210DHS,DHL			1
49	26222208	SHUTTLE RACE ADJUSTING SHAFT				1
50	CS1000811SP	THRUST COLLAR				1
51	SS8110520TP	SCREW 11/64-40 L= 4.5				2
52	CS080081CSH	THRUST COLLAR ASM. D=8.0 W=8				1
53	NS6660430SP	NUT 1/4-40				1
54	RE0900000K0	E-RING 9				1
55	SD0801021TP	HINGE SCREW D= 8 H=10.2				1
56	SS6060410TP	SCREW 3/32-56 L= 3.5				2
57	SS6121212TP	SCREW 3/16-28 L=12.0				1
58	SS6151220SP	SCREW 15/64-28 L=11.5				1
59	B1811210DA0	SHUTTLE DRIVER SHAFT ASM.				1

WIPER MECHANISM COMPONENTS

No.	Parts No.	Parts name	Remarks	Level	Cons	Qty
1	B2107210DA0	WIPER ASM.				1
2	B2107210D00	WIPER		*		1
3	B2111210D00	WIPER SHAFT CAP		*		1
4	22955504	WIPER COVER		*		1
5	40034676	WIPER BASE ASM		*		1
6	11110301	WIPER SOLENOID		*		1
7	22955900	WIPER RUBBER A		*		1
8	22956007	WIPER RUBBER B		*		1
9	22956106	WIPER LINK A		*		1
10	22956205	WIPER HINGE SCREW COLLAR		*		1
11	B2130210D00	WIPER SPRING		*		1
12	22956403	WIPER LINK B		*		1
13	11111051	WIPER DRIVING SHAFT ASM.		*		1
14	22956908	WIPER LINK B HINGE SCREW		*		1
15	22957104	WIPER SOLENOID SHAFT		*		1
16	22957203	WIPER LINK COLLAR		*		1
17	HK034610020	2-POLE NYLON PLUG		*		1
18	HK03464000B	PIN CONTACT		*		2
19	HA000590000	POWER SWITCH		*		1
20	HW200390000	ELECTRIC WIRE		*		0.1
21	HW500070000	2-CORE CABTYRE CORD		*		1.2
22	WS0310002KR	SPRING WASHER 3.1X5.9X0.7		*		3
23	NS6090310SP	NUT 9/64-40		*		1
24	NS6110310SP	NUT 11/64-40		*		1
25	RE0250000K0	E-RING 2.5		*		1
26	RE0500000K0	E-RING		*		1
27	SS6090620TP	SCREW		*		1
28	SS8110422TP	SCREW 11/64-40 L=4		*		1
29	SD0650321TP	HINGE SCREW D=6.5 H=3.2		*		1
30	SM4030601SN	SCREW M3 X 6		*		1
31	SM4030601SN	SCREW M3 X 6		*		3
32	WP0320501SC	WASHER M3		*		1
33	B2110210D00	WIPER SHAFT SUPPORT BRACKET				1
34	17700402	FACE COVER JOINT				1
35	B3549850000	LOOPER COVER OIL SHIELD STUD				1
36	SS7110840SP	SCREW 11/64-40 L=7.8				2
37	SS7110910SP	SCREW 11/64-40 L=8.5				2
38	WP0450801SD	WASHER 4.5X10X0.8				2
39	WP0482086SD	WASHER 4.8X11.5X2				1

TENSION RELEASE & THREAD TENSION COMPONENTS

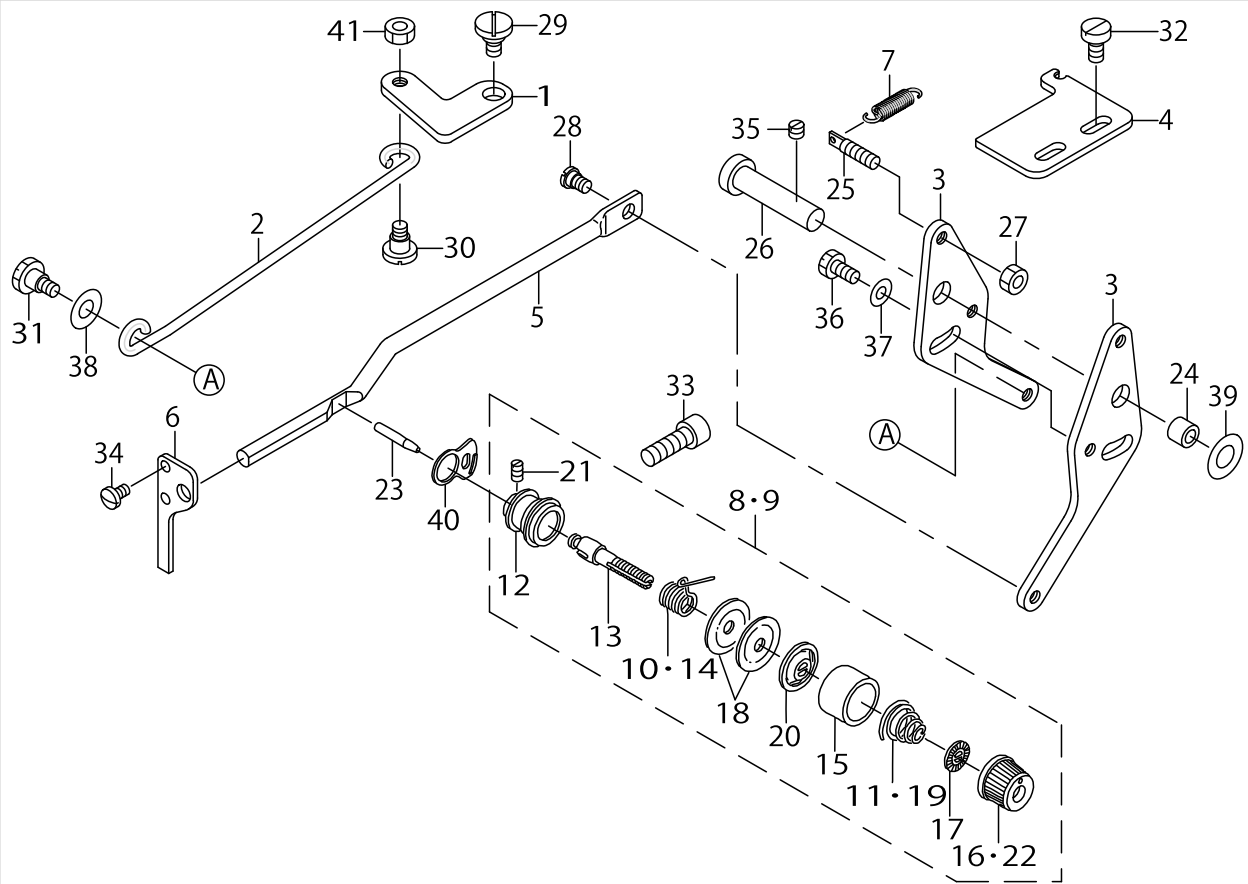

TENSION RELEASE & THREAD TENSION COMPONENTS

No.	Parts No.	Parts name	Remarks	Level	Cons	Qty
1	B2304210D00	TENSION RELEASE LINK				1
2	B2308210D00	TENSION RELEASE CONNECTING ROD				1
3	26500900	TENSION RELEASE ADJUSTING ARM				2
4	B2315210D00	STOPPER PLATE				1
5	13513205	TENSION RELEASE BAR				1
6	13513304	THREAD TENSION ARM				1
7	13716808	SPRING				1
8	B23022800A0	SECOND THREAD TENSION ASM.	FOR 210DSS,DSL			1
9	B23022050AA	SECOND THREAD TENSION.	FOR 210DHS,DHL			1
10	D3112L4BB00	TAKE-UP SPRING (HEAVY)	FOR 210DHS,DHL	*		1
11	B2305205000	TENSION SPRING	FOR 210DHS,DHL	*		1
12	B2313280000	THREAD TENSION ROD, LARGE		*		1
13	B2302280000	SECOND THREAD TENSION ROD		*		1
14	B3112761000	THREAD TAKE-UP SPRING	FOR 210DSS,DSL	*		1
15	B3107804000	THREAD TENSION DISK PRESSER	FOR 210DSS,DSL	*		1
16	B3119771000	THREAD TENSION NUT	FOR 210DSS,DSL	*		1
17	B3120125000	ROTATING STOPPER		*		1
18	B3126012000	THREAD TENSION DISK		*		2
19	B3114232000	THREAD TENSION SPRING	FOR 210DSS,DSL	*		1
20	B3132552000	THREAD TENSION DISK PRESSER		*		1
21	SS8090610SP	SCREW 9/64-40 L=5.9		*		1
22	13817408	THREAD TENSION NUT	FOR 210DHS,DHL	*		1
23	B2303280000	TENSION RELEASE PIN				1
24	B2619372000	STOP MOTION TRIPPING LEVER CAM				1
25	B1649161000	TENSION SPRING ADJUSTING SCREW				1
26	D2431555B00	THREAD TRIMMER SHAFT				1
27	NS6110310SP	NUT 11/64-40				1
28	SD0530221SP	HINGE SCREW D= 5.3 H= 2.2				1
29	SD0720321TP	HINGE SCREW				1
30	SD0640391TP	HINGE SCREW D= 6.35 H= 3.9				1
31	SD0640482SP	HINGE SCREW D= 6.35 H= 4.8				1
32	SS6120940SP	SCREW 3/16-28 L=9				2
33	SS6151812TP	SCREW 15/64-28 L=18				1
34	SS7090620TP	SCREW 9/64-40 L=6.1				2
35	SS8120410SP	SCREW 3/16-28 L=3.8				1
36	SS9110920CP	SCREW 11/64-40 L=9				1
37	WP0482086SD	WASHER 4.8X11.5X2				1
38	WP0651056SD	WASHER 6.5X11X1				1
39	WP0841600SE	WASHER 8,4X15,5X1,6				1
40	B2702210000	GUIDE PLATE				1
41	NS6120310SP	NUT 3/16-28				1

TENSION RELEASE & THREAD TRIMMER MECHANISM COMPONENTS

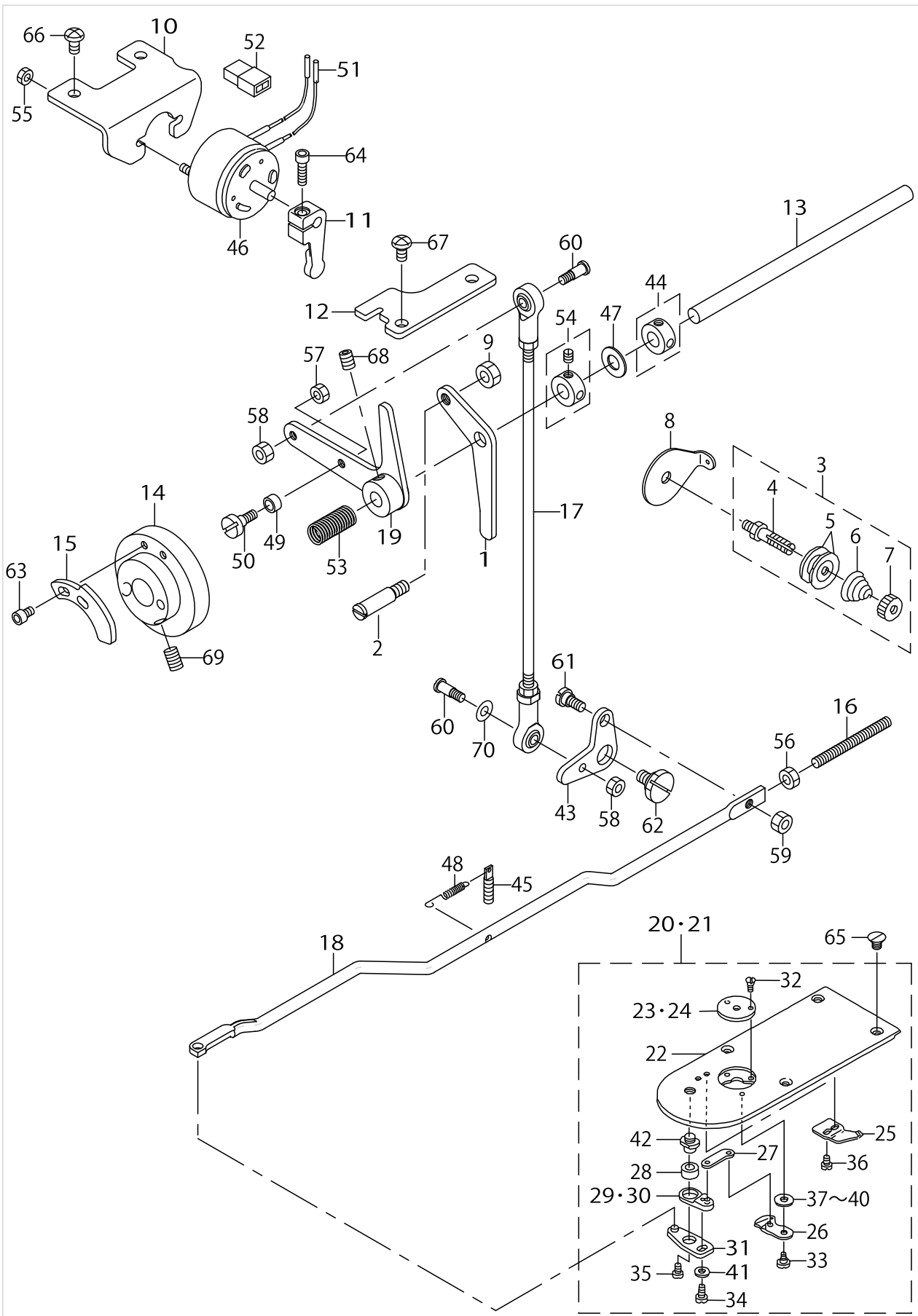

TENSION RELEASE & THREAD TRIMMER MECHANISM COMPONENTS

No.	Parts No.	Parts name	Remarks	Level	Cons	Qty
1	B2301210D00	TENSION RELEASE ARM				1
2	14107809	TENSION RELEASE ARM PIN				1
3	B11152320A0	FIRST THREAD TENSION ASM.				1
4	B3123352000	THREAD TENSION ROD		*		1
5	B3126012000	THREAD TENSION DISK		*		2
6	B1115232000	FIRST THREAD TENSION SPRING		*		1
7	B3125012000	THREAD TENSION NUT		*		1
8	B3111352000	UPPER LOOPER THREAD GUIDE				1
9	NS6150310SP	NUT 15/64-28				1
10	B2402210D00	MAGNET INSTALLING PLATE				1
11	B2409210D00	THREAD TRIMMER MAGNET ARM				1
12	B2412210D00	CAM INSTALLING LINK STOPPER				1
13	B2408210D00	THREAD TRIMMER SHAFT				1
14	B2401210D00	THREAD TRIMMER CAM				1
15	B2312210D00	TENSION RELEASE NOTCH				1
16	B2440210D00	LINK STOPPER SCREW				1
17	B2407210D00	THREAD TRIMMER CONNECTING ROD				1
18	B2413210D00	THREAD TRIMMER CONNECTING BAR				1
19	B2404210DA0	CAM INSTALLING LINK				1
20	B2425210DAA	NEEDLE PLATE ASM.	FOR 210DSS,DSL			1
21	B2425210DAB	NEEDLE PLATE H ASM.	FOR 210DHS,DHL			1
22	B2425210000	NEEDLE PLATE		*		1
23	B242621000A	NEEDLE HOLE GUIDE D=1.6	FOR 210DSS,DSL	*		1
24	B242621000B	NEEDLE HOLE GUIDE D=2.0	FOR 210DHS,DHL	*		1
25	B2424210000	COUNTER KNIFE		*		1
26	B2421210AA0	MOVING KNIFE COMPL.		*		1
27	B2418280000	MOVING KNIFE LINK		*		1
28	B2416280000	THREAD CUTTING LEVER RING		*		1
29	B24152800A0	THREAD CUTTER LEVER ASM., SMAL	FOR 210DSS,DSL	*		1
30	B24162100A0	THREAD CUTTER SMALL LEVER ASM.	FOR 210DHS,DHL	*		1
31	B24142800A0	THREAD CUTTER LEVER ASM., LARG		*		1
32	SS1060210TP	SCREW 3/32-56 L=2.2		*		2
33	B2417210000	MOVING KNIFE HINGE SCREW		*		1
34	SS7110740TP	SCREW 11/64-40 L=7		*		1
35	SS6110430TP	SCREW 11/64-40 L= 4.0		*		1
36	SS7090410SP	SCREW 9/64-40 L= 3.5		*		2
37	B242328000A	MOVING KNIFE WASHER A	SELECTIVE PARTS	*		1
38	B242328000B	MOVING KNIFE WASHER B	SELECTIVE PARTS	*		1
39	B242328000C	MOVING KNIFE WASHER C	SELECTIVE PARTS	*		1
40	B242328000D	MOVING KNIFE WASHER D	SELECTIVE PARTS	*		1
41	WP0450846SP	WASHER		*		1
42	B2417280000	THREAD CUTTER LEVER SHAFT		*		1
43	B2411210000	THREAD TRIMMER LINK				1
44	CS080081CSH	THRUST COLLAR ASM. D=8.0 W=8				1
45	B1649161000	TENSION SPRING ADJUSTING SCREW				1
46	B2303205000	SOLENOID				1
47	B1116804000	CLOTH PLATE WASHER				1

TENSION RELEASE & THREAD TRIMMER MECHANISM COMPONENTS

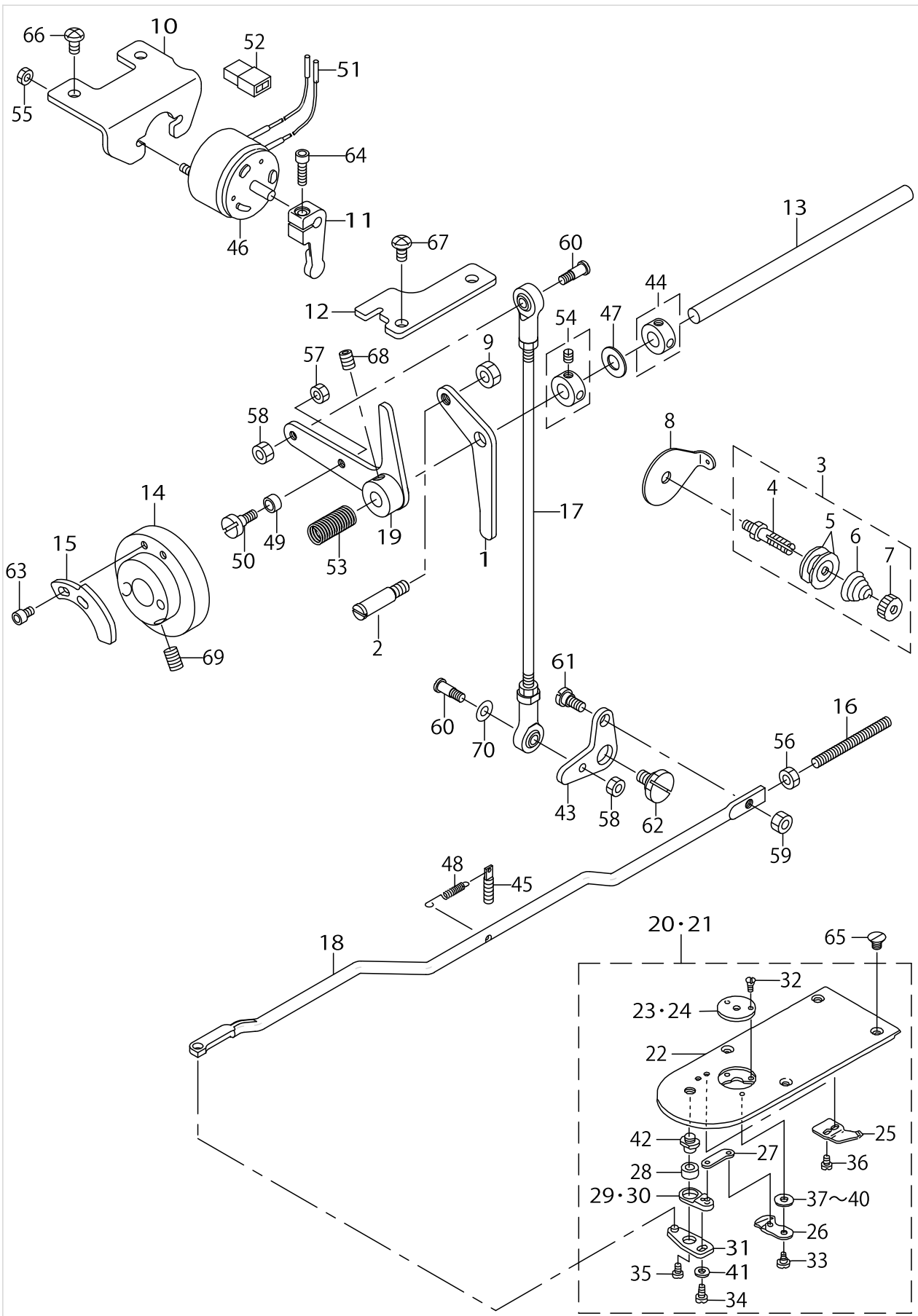

TENSION RELEASE & THREAD TRIMMER MECHANISM COMPONENTS

No.	Parts No.	Parts name	Remarks	Level	Cons	Qty
48	B2431215000	THREAD TRIMMER LINK SPRING				1
49	D2587L8WB00	ROLLER				1
50	D2588L8WB00	ROLLER SHAFT				1
51	HK034630000	TERMINAL				2
52	HK034620020	2P PLUG				1
53	B2617771000	TRIPPING LEVER TENSION SPRING				1
54	CS080081CSH	THRUST COLLAR ASM. D=8.0 W=8				1
55	NM6040003SC	NUT M4				2
56	NM6050001SP	NUT M5				1
57	NS6110420SP	NUT 11/64-40				1
58	NS6110420SP	NUT 11/64-40				2
59	NS6120630SP	NUT 3/16-28				1
60	SD0500803TP	HINGE SCREW D=5 H=8				2
61	SD0650305TP	HINGE SCREW D= 6.5 H= 3				1
62	SD1100301TP	HINGE SCREW H=11 W=3				1
63	SM6040602TP	SCREW M4 L=6				2
64	SM6041402TP	SCREW M4 L=14				1
65	SS1110640TP	SCREW 11/64-40 L= 5.5				4
66	SS4120915SP	SCREW 3/16-28 L=9				2
67	SS4120915SP	SCREW 3/16-28 L=9				2
68	SS8150822TP	SCREW 15/64-28 L=8				1
69	SS8661012TP	SCREW				2
70	WP0501016SD	WASHER 5X10.5X1				1

X-Y COMPONENTS (1)

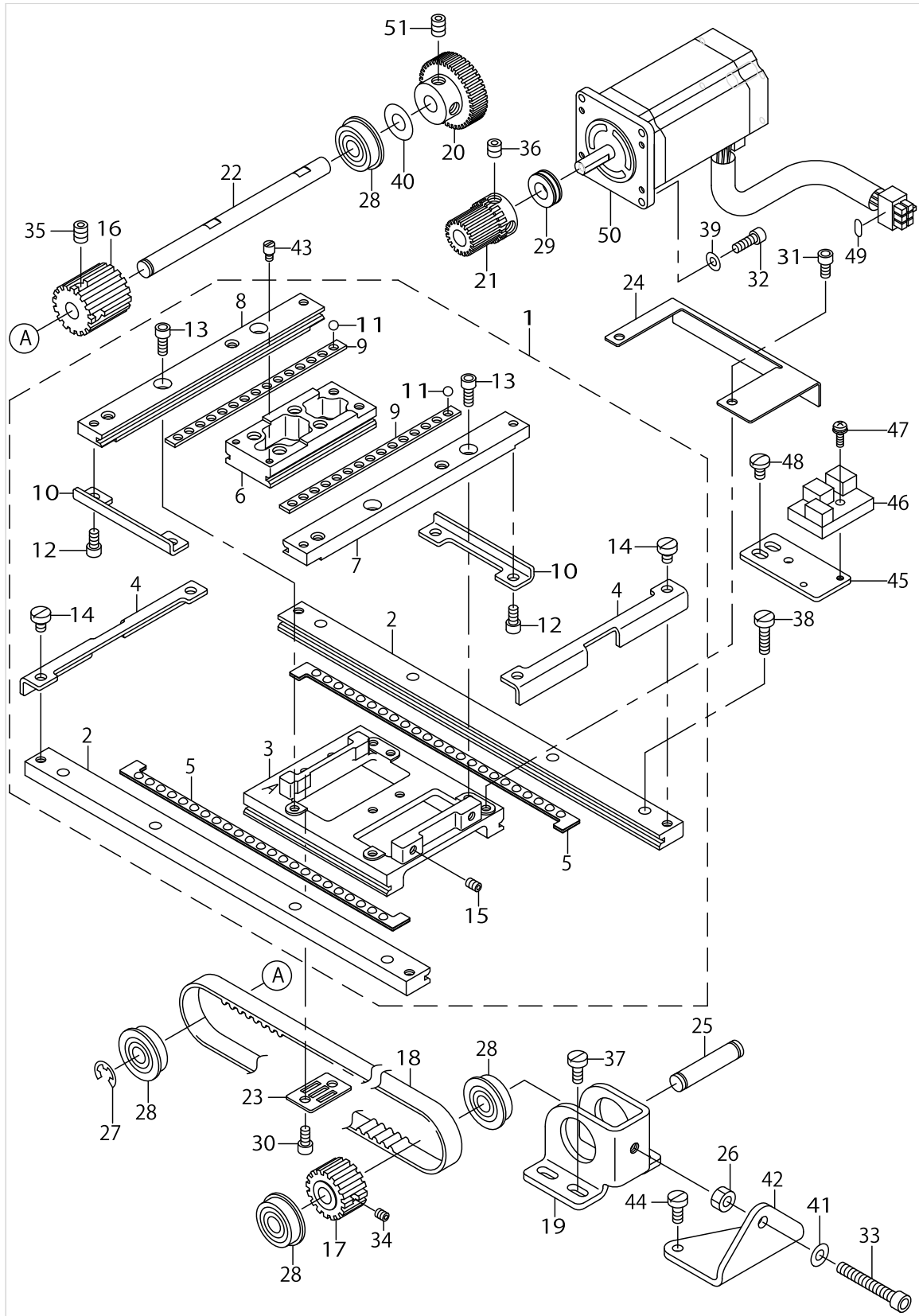

X-Y COMPONENTS (1)

No.	Parts No.	Parts name	Remarks	Level	Cons	Qty
1	B2501210DA0A	X-Y TABLE ASM.				1
2	B2501210D00	X FIXED RACE		*		2
3	B2502210D00A	RACE TABLE		*		1
4	B2507210D00	X STOPPER		*		2
5	B2508210DA0	X BALL GAUGE ASM.		*		2
6	B2519210D00	Y REMOVAL RACE		*		1
7	B2520210D0A	Y FIXED RACE,RIGHT		*		1
8	B2520210D0B	Y FIXED RACE,LEFT		*		1
9	B2521210D00	Y BALL GAUGE		*		2
10	B2522210D00	Y STOPPER		*		2
11	B2527210000	BALL		*		30
12	SM6040802TP	SCREW M4X0.7 L=8		*		4
13	SM6041002TP	SCREW M4 L=10		*		4
14	SS6110610TP	SCREW 11/64-40 L=6		*		4
15	SM8040602TP	SCREW M4X0.7 L=6		*		2
16	B2513210D00A	DRIVE SPROCKET				1
17	B2514210D00A	DRIVEN SPROCKET				1
18	B2512210D00A	X TIMING BELT				1
19	B2505210D00	X DRIVEN BRACKET				1
20	B2534210D00	X DRIVEN GEAR				1
21	B2526210D00	X DRIVE GEAR				1
22	B2506210D00	X DRIVE SHAFT				1
23	B2509210D00	BELT RECEIVER				1
24	B4007210D00	X SENSOR SLIT				1
25	13518105	LIFTING LEVER SHAFT				1
26	NM6050001SP	NUT M5				1
27	RE0600000K0	E-RING 6				1
28	SB108000500	RADIAL BEARING				4
29	SB408000100	BEARING				1
30	SM6040802TP	SCREW M4X0.7 L=8				2
31	SM6040602TP	SCREW M4 L=6				2
32	SM6041202TP	SCREW M4X0.7 L=12				4
33	SM6053502TP	BOLT				1
34	SM8040502TP	SCREW M4X0.7 L=5				1
35	SM8060802TP	SCREW M6 L=8				2
36	SM8060602TP	SCREW M6X6				2
37	SS6111010SP	SCREW 11/64-40 L= 9.5				4
38	SS6111620SP	SCREW 11/64-40 L=16.0				8
39	WP0450846SP	WASHER				4
40	WP0820526SD	WASHER 8.2X14X0.5				1
41	WP0531001SC	WASHER				1
42	B2530210D00	X BELT ADJUSTING BRACKET				1
43	B151902600G	HINGE STUD				2
44	SS6111010SP	SCREW 11/64-40 L= 9.5				2
45	B4004210D00	X SENSOR INSTALLING PLATE				1
46	HD00057000A	PHOTO SENSOR				1
47	SL4031081SF	SCREW M3 L=10				1

X-Y COMPONENTS (1)

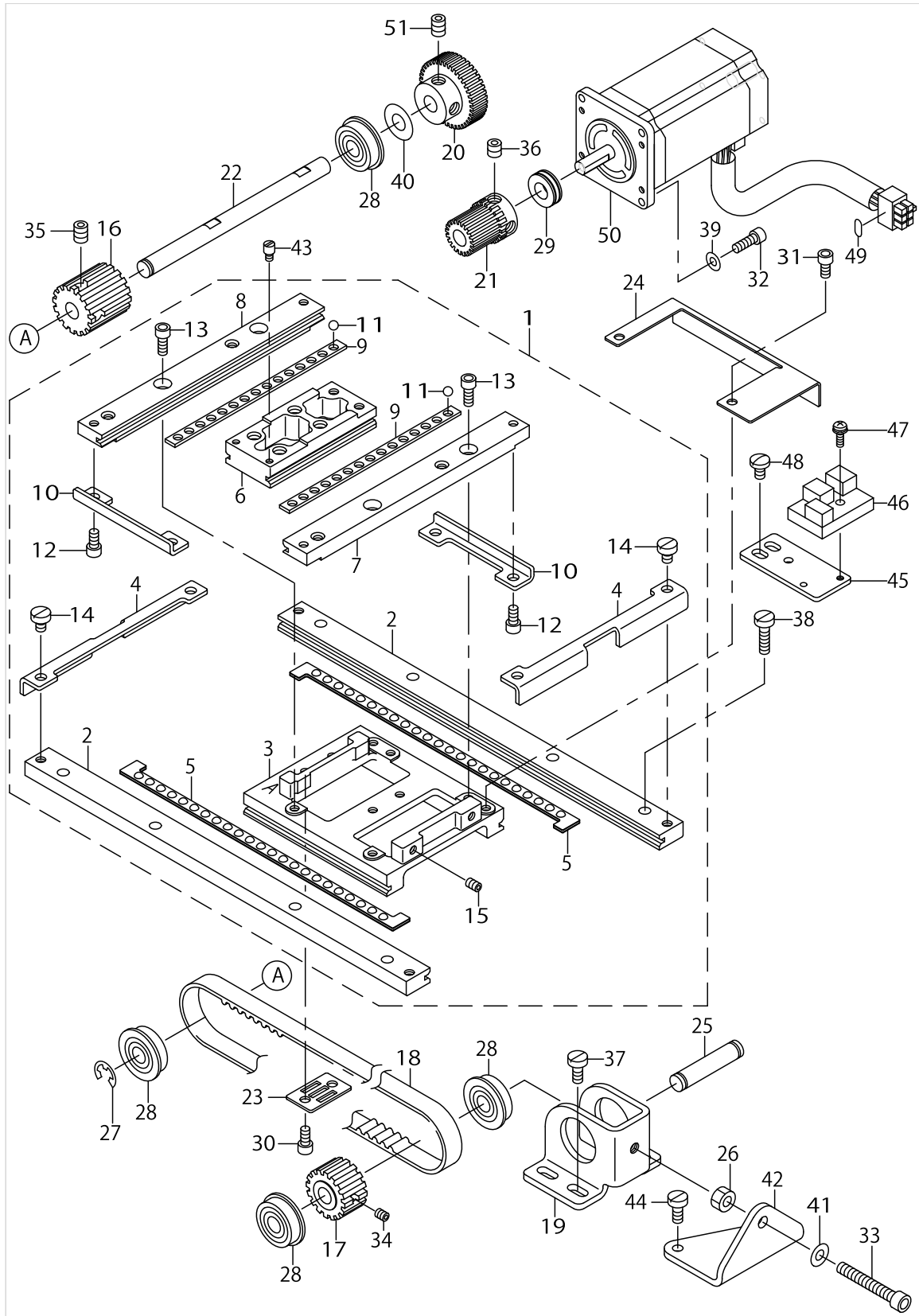

X-Y COMPONENTS (1)

No.	Parts No.	Parts name	Remarks	Level	Cons	Qty
48	SS7110710SP	SCREW 11/64-40 L=7				2
49	E2650453000	CONNECTOR MARKER J50				1
50	B2529210D00	FEED STEPPING MOTOR				1
51	SM8060802TP	SCREW M6 L=8				2

X-Y COMPONENTS (2)

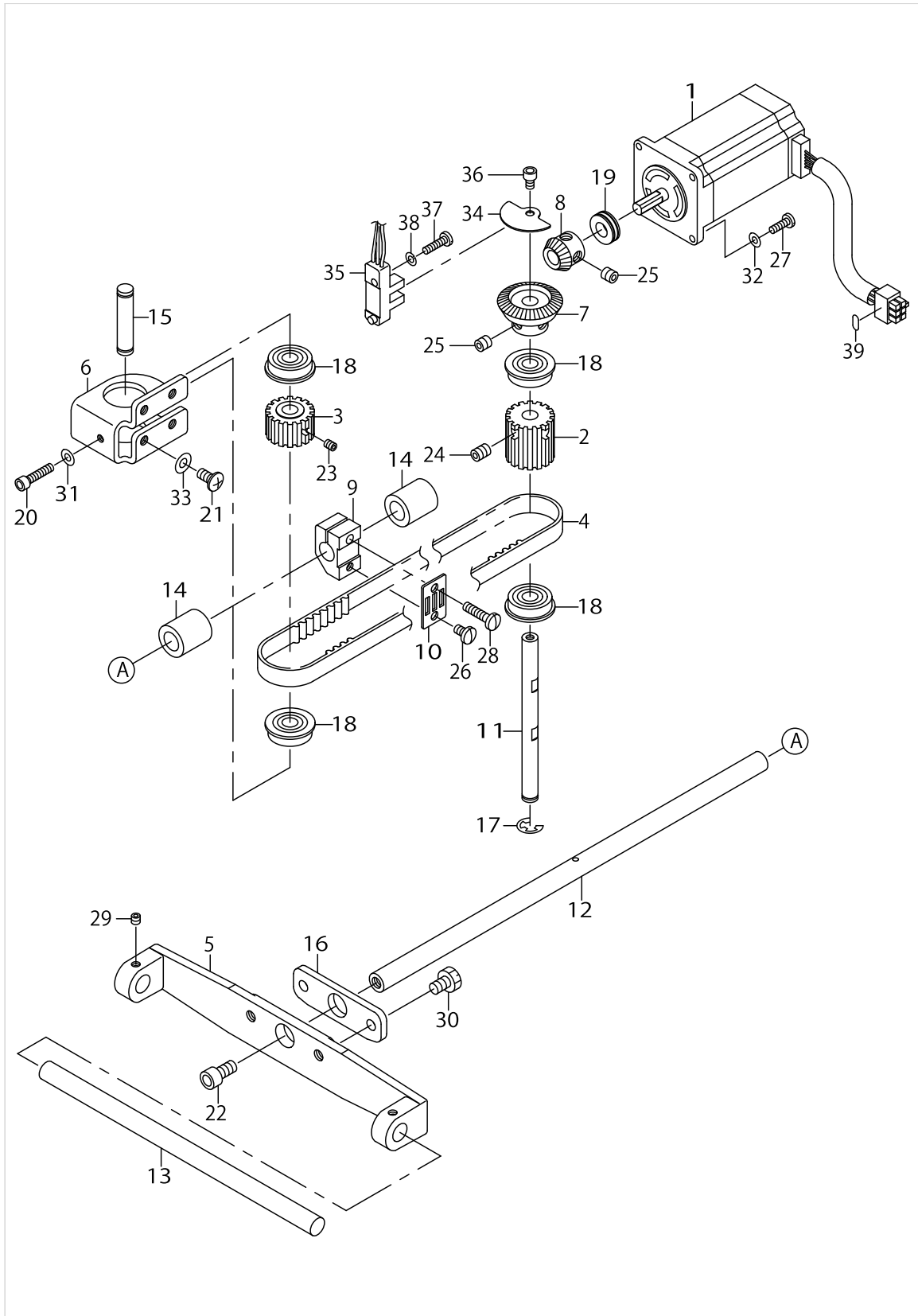

X-Y COMPONENTS (2)

No.	Parts No.	Parts name	Remarks	Level	Cons	Qty
1	B2529210D00	FEED STEPPING MOTOR				1
2	B2513210D00A	DRIVE SPROCKET				1
3	B2514210D00A	DRIVEN SPROCKET				1
4	B2528210D00A	Y TIMING BELT				1
5	B2511210D00	X GUIDE SHAFT BRACKET				1
6	B2518210D00	Y DRIVEN BRACKET				1
7	B2548210D00	Y DRIVEN GEAR				1
8	B2525210D00	Y DRIVE GEAR				1
9	B2536210D00A	Y BELT BRACKET				1
10	B2509210D00	BELT RECEIVER				1
11	B2523210D00	Y DRIVE SHAFT				1
12	B2524210D00	Y REMOVAL SHAFT				1
13	B2510210D00	X GUIDE SHAFT				1
14	B2509704000	BUSHING, REAR				2
15	13518105	LIFTING LEVER SHAFT				1
16	B2525205000	Y REMOVAL BRACKET				1
17	RE0600000K0	E-RING 6				1
18	SB108000500	RADIAL BEARING				4
19	SB408000100	BEARING				1
20	SM6041802TP	SCREW M4 L=18				1
21	SM0051001SC	SCREW				4
22	SM6061202TP	SCREW M6 L=12				1
23	SM8040502TP	SCREW M4X0.7 L=5				1
24	SM8060802TP	SCREW M6 L=8				2
25	SM8060602TP	SCREW M6X6				4
26	SS7110720SP	SCREW 11/64-40 L=7				1
27	SS7091110SP	SCREW 9/64-40 L=10.5				4
28	SS7111810TP	SCREW 11/64-40 L=18				1
29	SS8110422TP	SCREW 11/64-40 L=4				2
30	SS9150910SP	SCREW				2
31	WP0430801SC	WASHER 4.3X9X0.8				1
32	WP0450846SP	WASHER				4
33	WP0551016SH	WASHER 5.5X13X1				4
34	B4008210D00	Y SENSOR SLIT				1
35	HD002230000	PHOTO SENSOR				1
36	SM6040602TP	SCREW M4 L=6				1
37	SS7091410SP	SCREW 9/64-40 L=13.5				1
38	WS0410002KP	SPRING WASHER				1
39	E2651453000	CONNECTOR MARKER J51				1

CLOTH FEED MECHANISM COMPONENTS(FOR 210DSS,210DHS)

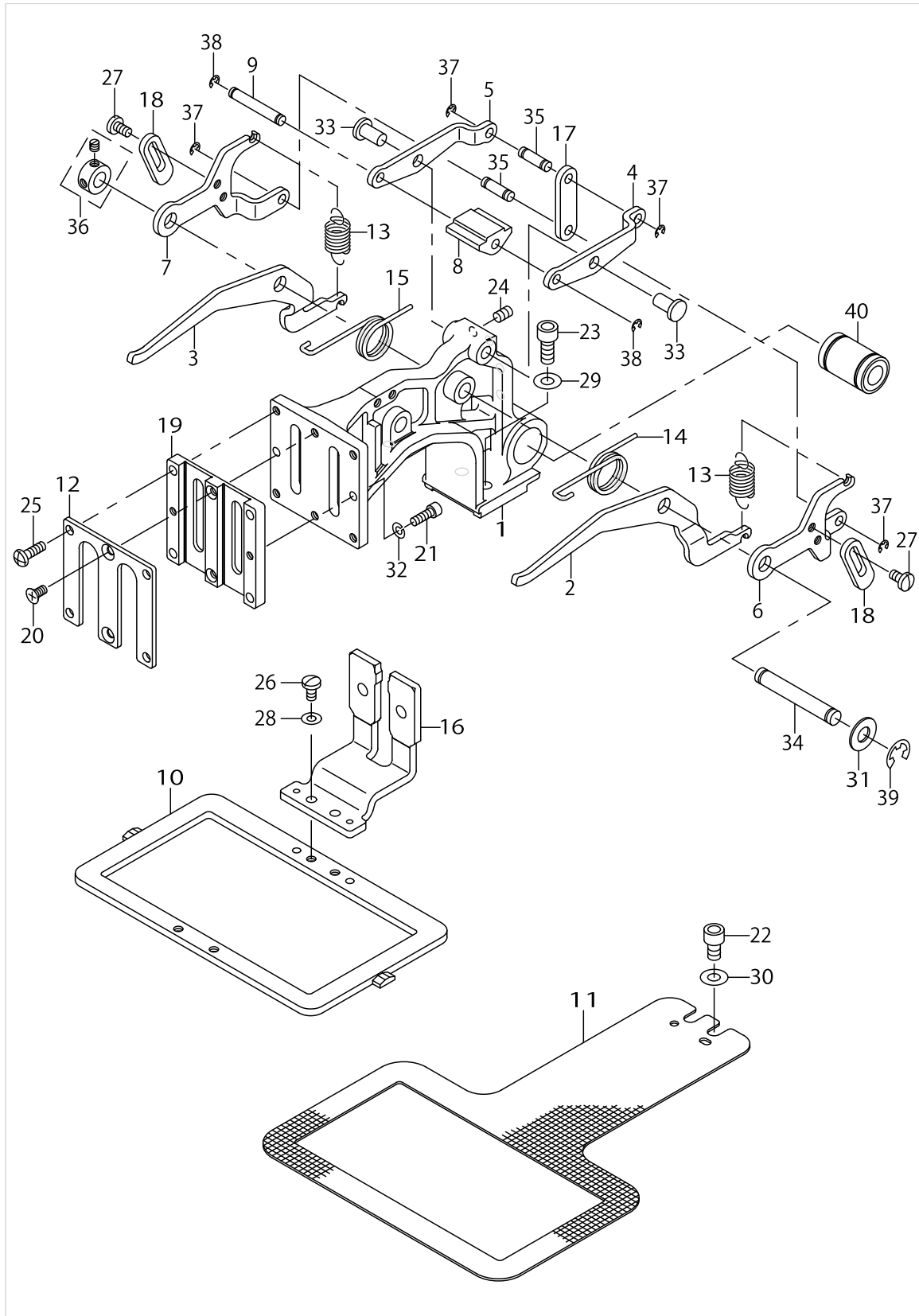

CLOTH FEED MECHANISM COMPONENTS(FOR 210DSS,210DHS)

No.	Parts No.	Parts name	Remarks	Level	Cons	Qty
1	B2550210D00	FEED BRACKET				1
2	B2570210D00	LIFTING LEVER,RIGHT				1
3	B2571210D00	LIFTING LEVER,LEFT				1
4	B2577210D00	FEED BRACKET UPPER LINK,RIGHT				1
5	B2578210D00	FEED BRACKET UPPER LINK,LEFT				1
6	B2574210D00	SUPPORT LINK,RIGHT				1
7	B2575210D00	SUPPORT LINK,LEFT				1
8	B2579210D00A	SLIDER				1
9	B2573210D00	SLIDER SHAFT				1
10	B2553210D00	FEEDING FRAME				1
11	B2552210D00	LOWER PLATE				1
12	B2572210D00	WORK CLAMP FOOT PLATE COVER				1
13	B2583210D00	SPRING				2
14	B2581210D00	SPRING,RIGHT				1
15	B2582210D00	SPRING,LEFT				1
16	B2551210DA0A	SLIDE PLATE COMPL.				1
17	B2576210D00	FEED BRACKET LINK				1
18	B2580210D00	LINK STOPPER				2
19	B2610210D00	WORK CLAMP FOOT PLATE				1
20	SM1040801SP	SCREW M4X0.7 L=8				2
21	SM6041202TP	SCREW M4X0.7 L=12				2
22	SM6061002TP	SCREW M6 L=10				2
23	SM6061402TN	BOLT				2
24	SM8050802TP	SCREW M5X0.8 L=8				2
25	SS4111415SP	SCREW 11/64-40 L=14				4
26	SS7110840SP	SCREW 11/64-40 L=7.8				2
27	SS7110840SP	SCREW 11/64-40 L=7.8				4
28	WP0480856SP	WASHER 4.8X8.4X0.8				2
29	WP0651001SC	WASHER				2
30	WP0651001SC	WASHER				2
31	B255728000C	WASHER				1
32	WS0410002KP	SPRING WASHER				2
33	B1626555000	FEED REGULATOR CONNECTING ROD				2
34	D2502232D00	SHAFT BLOCK SHAFT				1
35	B1626220000	CYLINDER PIN				2
36	CS079073ASH	THRUST COLLAR ASM.				1
37	RE0300000K0	E-RING 3				4
38	RE0300000K0	E-RING 3				2
39	RE0700000K0	E-RING 7				1
40	SB710000200	SLIDE BEARING				1

CLOTH FEED MECHANISM COMPONENTS(FOR 210DSL,210DHL)

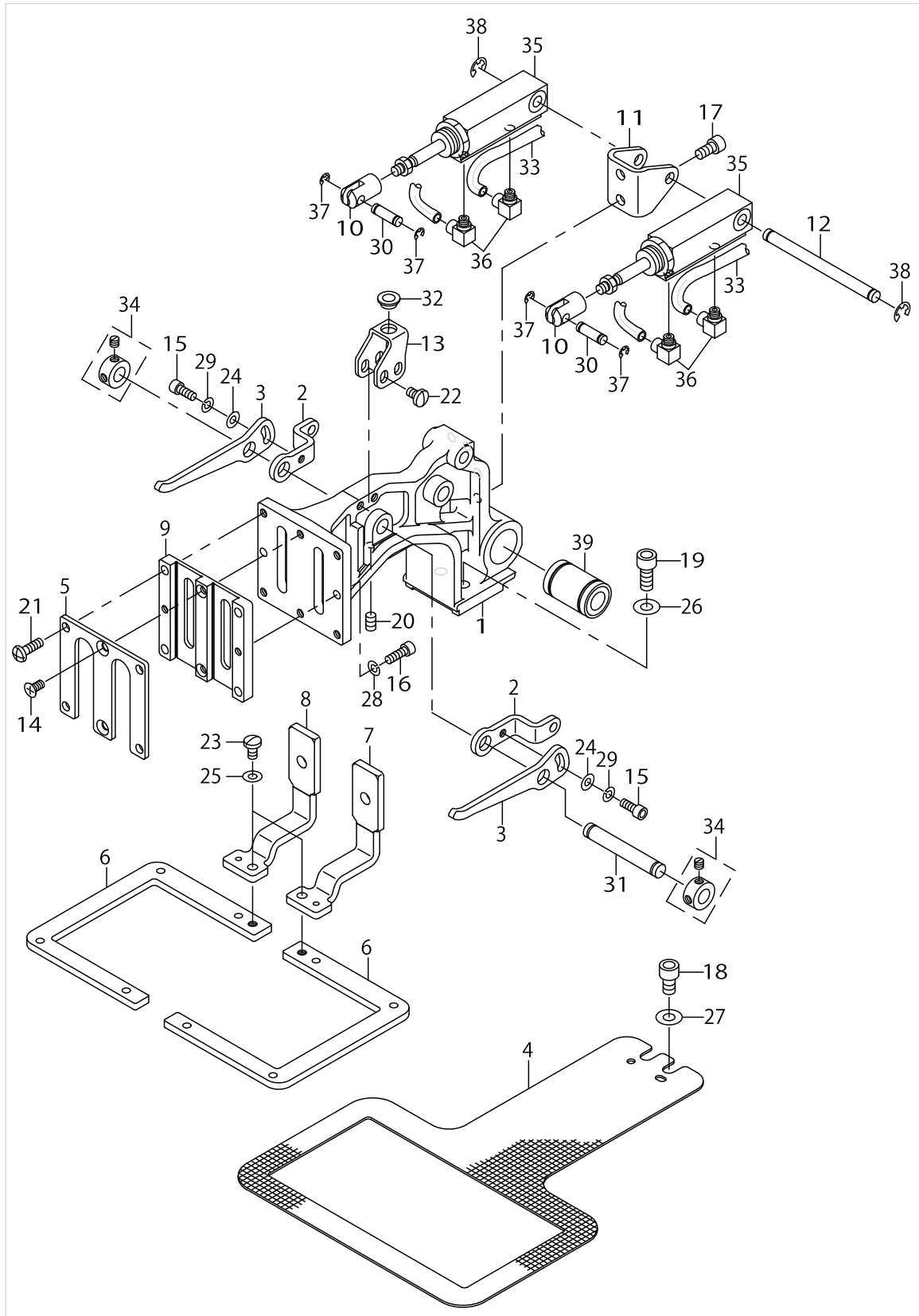

CLOTH FEED MECHANISM COMPONENTS(FOR 210DSL,210DHL)

No.	Parts No.	Parts name	Remarks	Level	Cons	Qty
1	B2550210D00	FEED BRACKET				1
2	B2564210D00	LINK PLATE A				2
3	B2560210D00	LINK PLATE B				2
4	B2552210D00	LOWER PLATE				1
5	B2572210D00	WORK CLAMP FOOT PLATE COVER				1
6	B2554210D00	FEEDING FRAME				2
7	B2590210DA0	WORK CLAMP FOOT COMPL.,RIGHT				1
8	B2591210DA0	WORK CLAMP FOOT COMPL.,LEFT				1
9	B2610210D00	WORK CLAMP FOOT PLATE				1
10	B2566210D00	CYLINDER KNUCKLE				2
11	B2567210D00	CYLINDER INSTALLING BASE				1
12	B2561210D00	CYLINDER SHAFT				1
13	B2562210D00	SLIDER BASE				1
14	SM1040801SP	SCREW M4X0.7 L=8				2
15	SM6041002TP	SCREW M4 L=10				2
16	SM6041202TP	SCREW M4X0.7 L=12				2
17	SM6051002TP	SCREW M5X0.8 L=10				2
18	SM6061002TP	SCREW M6 L=10				2
19	SM6061402TN	BOLT				2
20	SM8050812TP	SCREW M5X8				1
21	SS4111415SP	SCREW 11/64-40 L=14				4
22	SS7110710SP	SCREW 11/64-40 L=7				4
23	SS7110840SP	SCREW 11/64-40 L=7.8				2
24	WP0450000SD	WASHER 4.5X8X0.5				2
25	WP0480856SP	WASHER 4.8X8.4X0.8				2
26	WP0651001SC	WASHER				2
27	WP0651001SC	WASHER				2
28	WS0410002KP	SPRING WASHER				2
29	WS0410002KP	SPRING WASHER				2
30	B1626220000	CYLINDER PIN				2
31	D2502232D00	SHAFT BLOCK SHAFT				1
32	G5126172000	CLAMP SHAFT HOLDER				1
33	BT0400251EB	URETHANE HOSE, BLACK				4
34	CS079073ASH	THRUST COLLAR ASM.				2
35	PA1602006A0	AIR CYLINDER				2
36	PJ046052503	HOSE ELBOW				4
37	RE0300000K0	E-RING 3				4
38	RE0500000K0	E-RING				2
39	SB710000200	SLIDE BEARING				1

PNEUMATIC COMPONENTS(FOR 210DSL,210DHL)

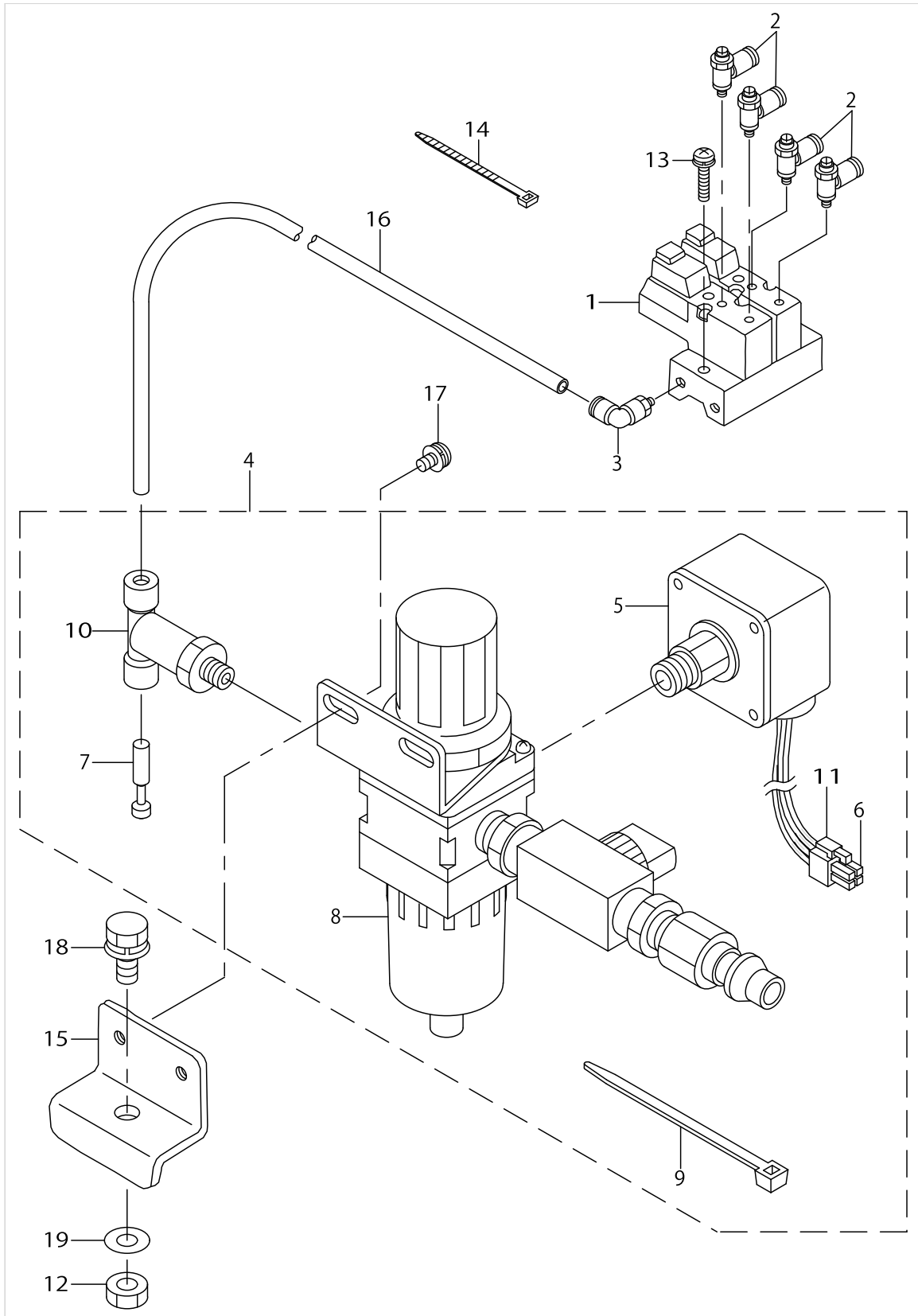

PNEUMATIC COMPONENTS(FOR 210DSL,210DHL)

No.	Parts No.	Parts name	Remarks	Level	Cons	Qty
1	PV0351130A0	SOLENOID VALVE ASM.				1
2	PC010507000	SPEED CONTROLLER				4
3	PJ304065101	ELBOW UNION 6XPT1/8				1
4	B47152150A0	FILTER REGULATOR ASM.				1
5	G8124270000	AIR PRESSUE SWITCH		*		1
6	HK034640000	PIN CONTACT		*		3
7	PX950009000	PLUG		*		1
8	PF0552040B0	FILTER REGULATOR		*		1
9	EA9500B0100	CABLE BAND		*		5
10	PJ305065202	TEE		*		1
11	HK034610040	HOUSING		*		1
12	NM6080721SE	NUT M8				1
13	SL4042081SC	SCREW				2
14	EA9500B0100	CABLE BAND				1
15	B8211206000	FILTER INSTALLING PLATE				1
16	BT0600401EB	TUBE				1
17	SL4051091SC	SCREW M5X0.8 L=10				2
18	SL9082093SE	SCREW				1
19	WP0871602SE	WASHER 8.7X18X1.6				1

LUBRICATION COMPONENTS

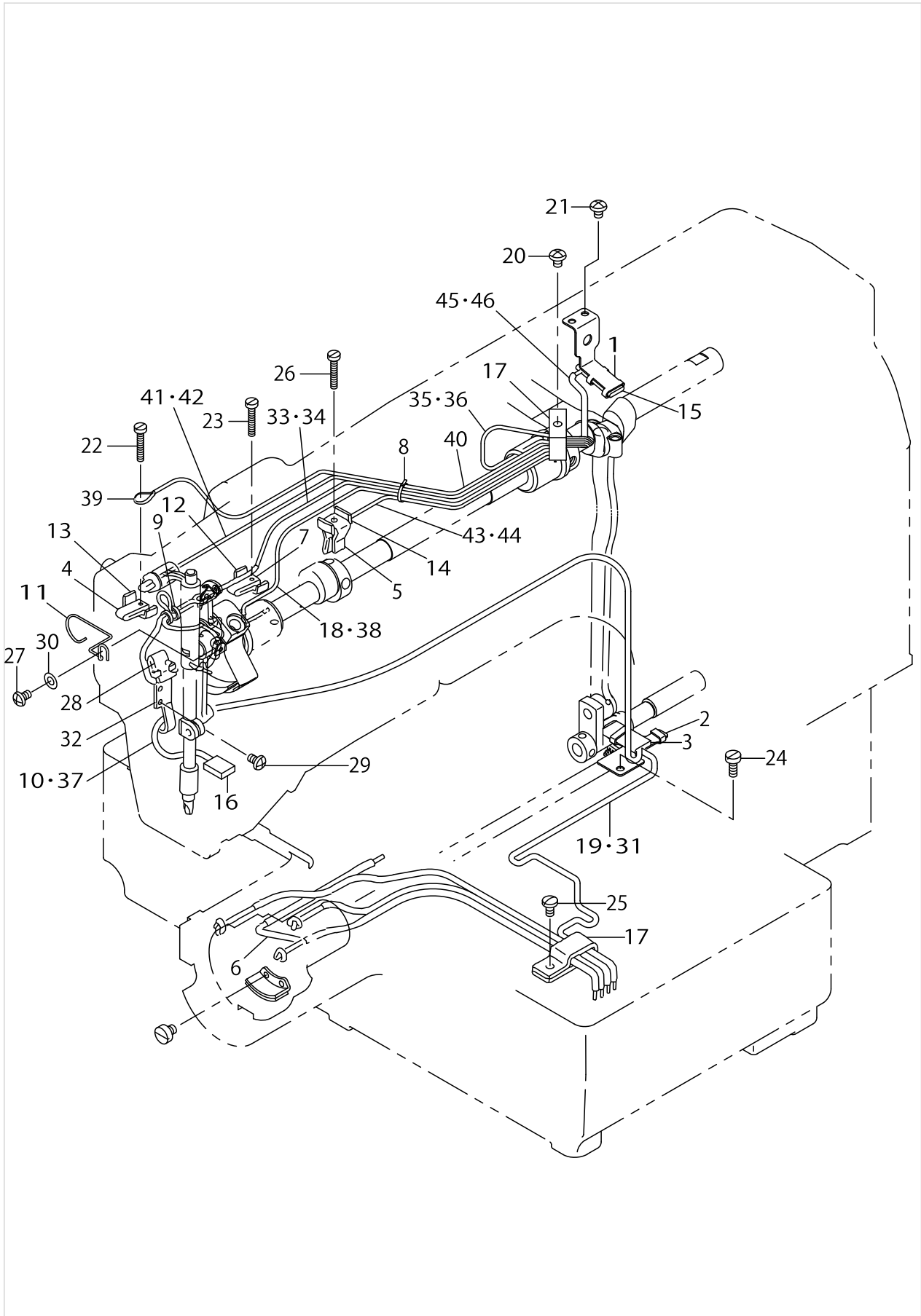

LUBRICATION COMPONENTS

No.	Parts No.	Parts name	Remarks	Level	Cons	Qty
1	B3505210D00	CRANK ROD LUBRICATION PLATE				1
2	B3506210D00	LUBRICATION PLATE				1
3	B3509210D00	OIL FELT				1
4	B3518280000	BALANCE LUBRICATING				1
5	B3520220000	OIL SPONGE				1
6	B35222100A0	OIL FELT ASM.				1
7	B3518280000	BALANCE LUBRICATING				1
8	EA9500B0100	CABLE BAND				1
9	26230706	OIL WICK PRESSER				3
10	B3523220000	OIL FELT				1
11	B3507220000	OIL WICK HOLDER				1
12	B3508280000	BALANCE LUBRICATING PLATE				1
13	B3508280000	BALANCE LUBRICATING PLATE				1
14	B3508280000	BALANCE LUBRICATING PLATE				1
15	B3509280000	NEEDLE ROD CRANK LUBRICATING				1
16	B3507280000	OIL FELT				1
17	D2112555B00	CORD HOLDER, LARGE				2
18	CQ200000000	OIL WICK				1.2
19	CQ252200000	OIL WICK				0.65
20	SS4120615SP	SCREW 3/16-28 L=6				1
21	SS4120615SP	SCREW 3/16-28 L=6				2
22	SS6092120SP	SCREW 9/64-40 L=21.2				1
23	SS6092120SP	SCREW 9/64-40 L=21.2				1
24	SS6111140SP	SCREW 11/64-40 L=11				2
25	SS7110840SP	SCREW 11/64-40 L=7.8				1
26	SS6092120SP	SCREW 9/64-40 L=21.2				1
27	SS4110715SP	SCREW 11/64-40 L=7				1
28	B3509220000	OIL SPONGE				1
29	SS4110715SP	SCREW 11/64-40 L=7				2
30	WP0450000SD	WASHER 4.5X8X0.5				1
31	BP300000000	VINYL PIPE				0.46
32	B3502220000	OIL WICK HOLDER				1
33	BP300000000	VINYL PIPE				0.27
34	CQ202000000	OIL WICK				1.3
35	CQ252200000	OIL WICK				0.35
36	BP300000000	VINYL PIPE				0.12
37	BP600000000	VINYL PIPE				0.4
38	BP300000000	VINYL PIPE				0.26
39	CQ200000000	OIL WICK				0.9
40	BP300000000	VINYL PIPE				0.3
41	CQ252200000	OIL WICK				0.6
42	BP300000000	VINYL PIPE				0.26
43	CQ252200000	OIL WICK				0.4
44	BP300000000	VINYL PIPE				0.2
45	CQ200000000	OIL WICK				0.6
46	BP300000000	VINYL PIPE				0.21

TABLE COMPONENTS

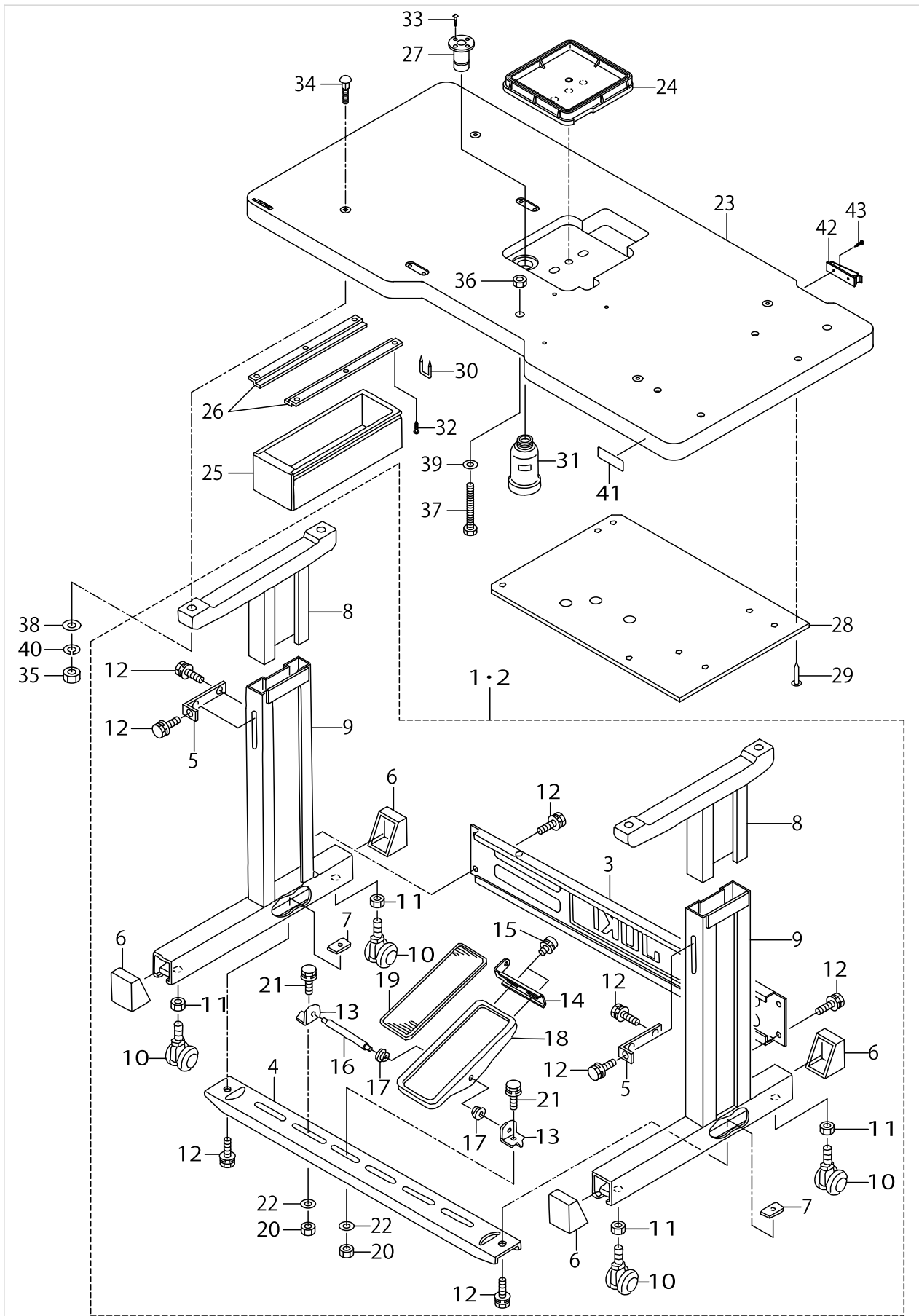
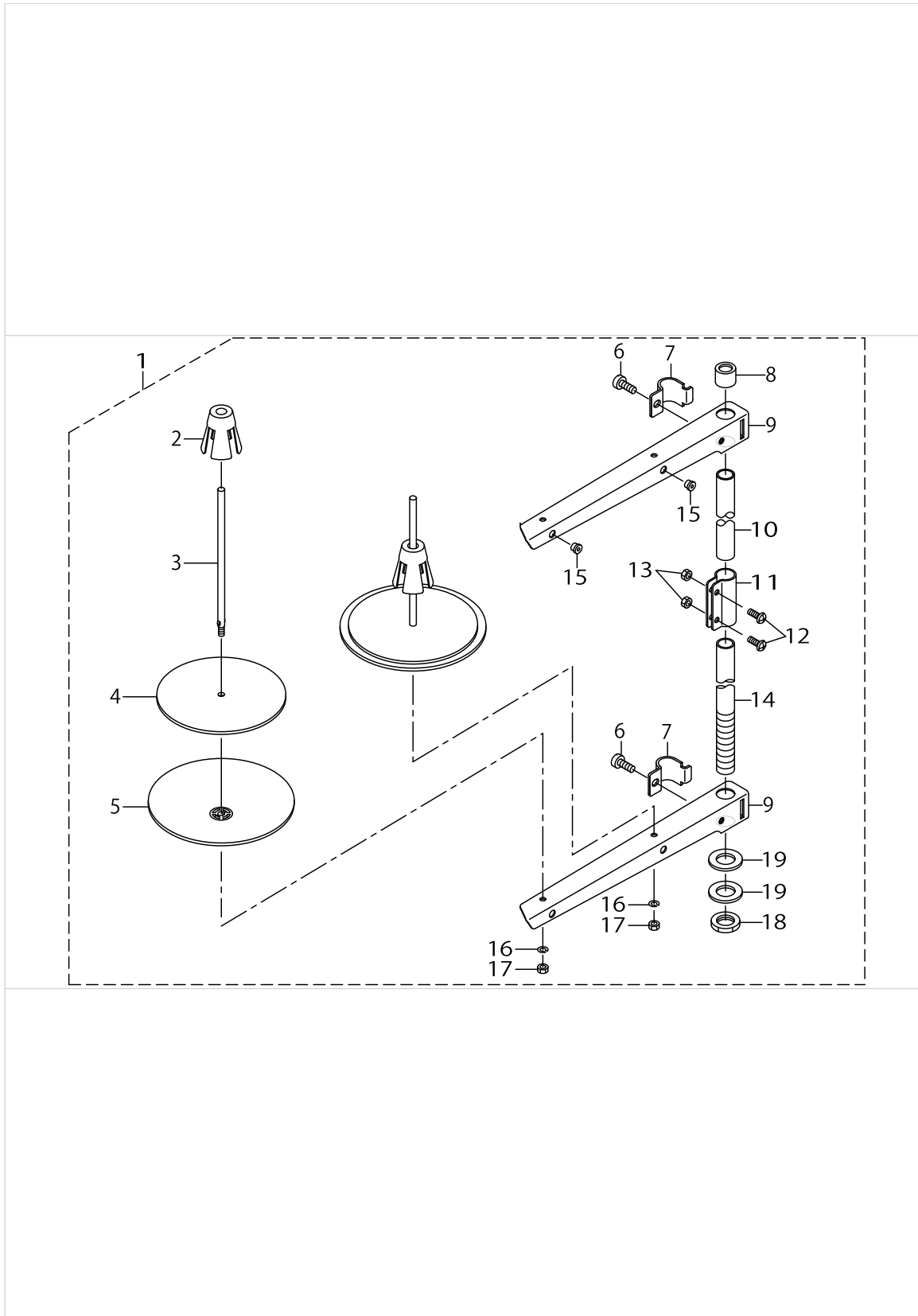

TABLE COMPONENTS

No.	Parts No.	Parts name	Remarks	Level	Cons	Qty
1	B8101210DA0	T-STAND ASM.(MAGNET TYPE)	FOR 210DSS,DHS			1
2	B8101210DAA	T-STAND ASM.(PNEUMATIC TYPE)	FOR 210DSL,DHL			1
3	11158300	STAND SIDE SUPPORT		*		1
4	11158409	STAND SIDE SUPPORT		*		1
5	11158516	UPPER STAND PLATE		*		2
6	11158607	RUBBER CAP		*		4
7	17007402	NUT		*		2
8	B8101210AAB	UPPER STAND ASM.		*		2
9	B8105210AAA	STAND ASM.		*		2
10	B8150210000	CASTER		*		4
11	NM6120003SE	NUT M12		*		4
12	SL9082093SE	SCREW		*		12
13	11159001	PEDAL SHAFT BRACKET	FOR 210DSS,DHS	*		2
14	GPF06080000	PEDAL ADJUSTING PLATE	FOR 210DSS,DHS	*		1
15	SL9061293SE	WASHER HEXAGONAL BOLT	FOR 210DSS,DHS	*		2
16	B8153771000	PEDAL CONNECTING ROD	FOR 210DSS,DHS	*		1
17	D8113555B00	PEDAL BUSHING	FOR 210DSS,DHS	*		2
18	GPF06060000	PEDAL	FOR 210DSS,DHS	*		1
19	GPF06070000	PEDAL MAT	FOR 210DSS,DHS	*		1
20	NM6080721SE	NUT M8	FOR 210DSS,DHS	*		2
21	SL9082093SE	SCREW	FOR 210DSS,DHS	*		2
22	WP0871602SE	WASHER 8.7X18X1.6	FOR 210DSS,DHS	*		2
23	B8201210D00A	TABLE				1
24	B8110221D00	OIL RESERVOIR				1
25	11155108	DRAWER				1
26	11155207	DRAWER SUPPORT				2
27	B8202205000	OIL MANAGEMENT				1
28	B8203205000A	TABLE EARTH PLATE				1
29	B8210012000	CUSHION SET NAIL				2
30	D8204555D00	DRAWER STOPPER				1
31	B9121012000	OIL CAN				1
32	SK3311600SC	WOOD SCREW D=3.1 L=16				6
33	SK3311600SC	WOOD SCREW D=3.1 L=16				2
34	MAO11108N00	PEDAL SWITCH FRAME BOLT				4
35	NM6060001SC	NUT M6				4
36	NM6080001SC	NUT M8X1.25				1
37	SM9086503SM	SCREW M8 L=65				1
38	WP0641601SC	WASHER				4
39	WP0851846SC	WASHER 8.5X22.0X1.8				1
40	WS0610002KN	SPRING WASHER 6.1X12.2X1.5				4
41	CM500100001	CE MARKING LABEL	FOR JE			1
42	M964051000A	CABLE CLIP				1
43	SK3382001SE	SCREW D=3.8 L=20				2

THREAD STAND COMPONENTS



THREAD STAND COMPONENTS

No.	Parts No.	Parts name	Remarks	Level	Cons	Qty
1	22930358	THREAD STAND ASM.				1
2	22931109	SPOOL RETAINER		*		2
3	22931000	SPOOL PIN		*		2
4	22930903	SPOOL REST CUSHION		*		2
5	22930804	SPOOL REST		*		2
6	SM6061610SC	SCREW M6 L=16		*		2
7	22930705	THREAD GUIDE ARM JOINT		*		2
8	22931406	SPOOL REST ROD RUBBER CAP		*		1
9	22930507	SPOOL REST ARM		*		2
10	22930408	SPOOL REST ROD, UPPER		*		1
11	22931307	SPOOL REST ROD JOINT		*		1
12	SM4051405SE	SCREW M5 L=14		*		2
13	NM6050001SE	NUT M5		*		2
14	22930309	SPOOL REST ROD, LOWER		*		1
15	22931208	THREAD GUIDE		*		2
16	WS0510002KN	SPRING WASHER		*		2
17	NM6050001SE	NUT M5		*		2
18	NM6160511SE	NUT M16X1.5		*		1
19	WP1702600S0	WASHER 17X30X2.6		*		2

OPERATION BOX COMPONENTS

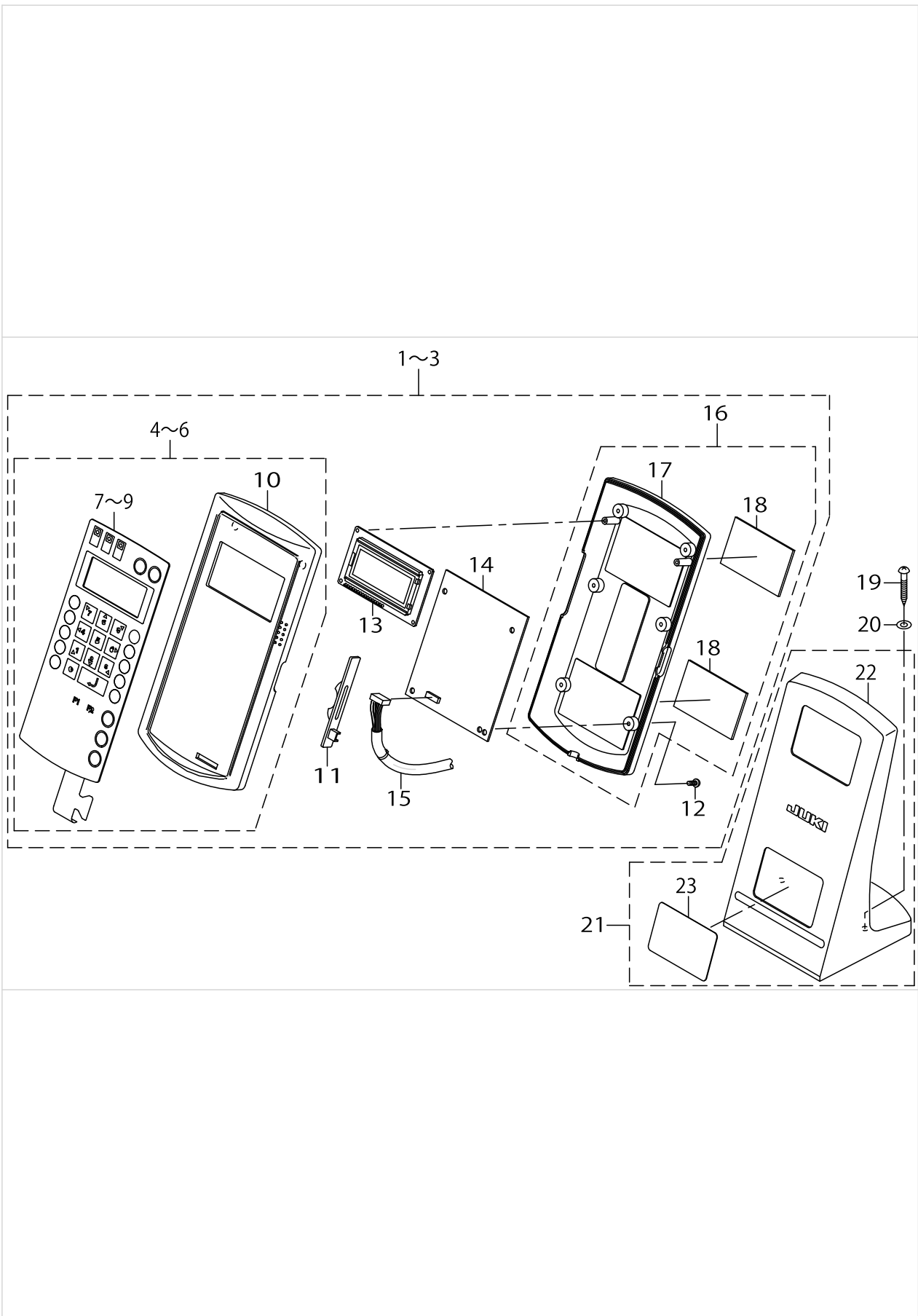

OPERATION BOX COMPONENTS

No.	Parts No.	Parts name	Remarks	Level	Cons	Qty
1	M8510580AA0	OPERATION BOX J ASM.	FOR USE IN JAPAN			1
2	M8510580BA0	OPERATION BOX E ASM.	FOR EXPORT(EXCEPT JHK)			1
3	40022185	OPERATION BOX C ASM.	FOR EXPORT(JHK)			1
4	M10305800A0	OPERATION BOX UPPER CASE A ASM	FOR USE IN JAPAN	*		1
5	M10305800B0	OPERATION BOX UPPER CASE B ASM	FOR EXPORT(EXCEPT JHK)	*		1
6	40022182	OPERATION BOX UPPER CASE ASM	FOR EXPORT(JHK)	*		1
7	M300558000AA	OPERATION PANEL SHEET (JPN)	FOR USE IN JAPAN	*		1
8	M300558000BA	OPERATION PANEL SHEET (ENG)	FOR EXPORT(EXCEPT JHK)	*		1
9	40022157	OPERATION PANEL SHEET (CHINA)	FOR EXPORT(JHK)	*		1
10	M1030580000A	OPERATION BOX UPPER CASE		*		1
11	M1032580000	VOLUME TONGUE		*		1
12	ST4031051SN	TAPPING SCREW D=3-24 L=10		*		6
13	M85415800A0	LCD ASM.		*		1
14	M86065800A0	OPERATION CIRCUIT BOARD ASM.		*		1
15	M90125800A0	PANEL SIGNAL CORD ASM.		*		1
16	M10315800A0	OPERATION BOX LOWER CASE ASM.		*		1
17	M1031580000	OPERATION BOX LOWER CASE		*		1
18	M1011580000	MAGNET SHEET		*		2
19	SK3451600SC	WOOD SCREW D=4.5 L=16				2
20	WP0501016SC	WASHER 5X10.5X1				2
21	M10175800A0	OPERATION BOX FIXED PLATE ASM.				1
22	M1017580000A	OPERATION BOX FIXED PLATE		*		1
23	M1019580000	OPERATION BOX FIXING PLATE		*		2

CONTROL BOX COMPONENTS

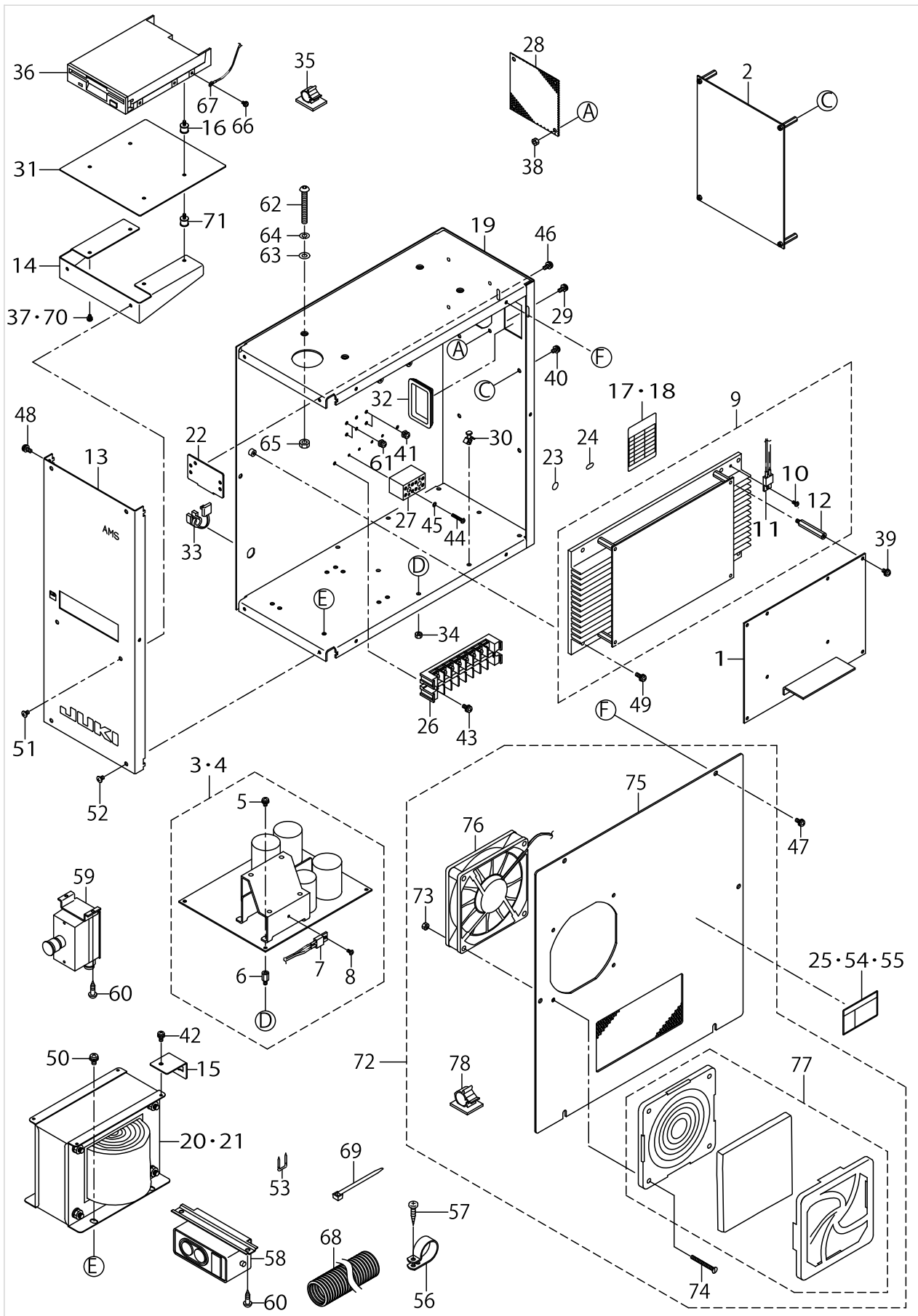

CONTROL BOX COMPONENTS

No.	Parts No.	Parts name	Remarks	Level	Cons	Qty
1	M8601580AA0	MAIN CIRCUIT BOARD A ASM.				1
2	40022269	SDC CIRCUIT BOARD ASM.				1
3	M86045900B0A	POWER CIRCUIT BOARD ASM.	FOR 100~200V			1
4	M8604590AB0A	POWER CIRCUIT BOARD A ASM.	FOR 380V			1
5	SL4030681SF	SCREW M3 L=6		*		4
6	HX00056000B	SPACER		*		4
7	M9012581AA0	THERMAL SWITCH A ASM.		*		1
8	SL4030681SF	SCREW M3 L=6		*		1
9	M86055800A0A	PMDC CIRCUIT BOARD ASM.				1
10	SL4030681SF	SCREW M3 L=6		*		1
11	M90125810A0	THERMAL SWITCH ASM.		*		1
12	HX00339000D	SPACER		*		4
13	M1003580000	CONTROL BOX PANEL				1
14	M1006580000	FDD MOUNT PLATE				1
15	M1014580000	CONNECTOR HOLDER PLATE				1
16	M2001580000	FDD VIBROISOLATING RUBBER	FOR 100~200V			4
17	M300551100A	SEAL A	FOR 100~200V			1
18	M300258000B	SEAL B	FOR 380V			1
19	M1001590000	CONTROL BOX				1
20	M8901580AA0A	TRANSFORMER A ASM.	FOR 100~200V			1
21	M8901580BA0A	TRANSFORMER B ASM.	FOR 380V			1
22	17845009	CORD FITTING PLATE				1
23	E9567319000	EARTH MARK				1
24	CM200100001	PE MARK LABEL	FOR 380V			1
25	CM300100001	LABEL	FOR 380V			1
26	HK026650080	TERMINAL BASE 8P	FOR 100~200V			1
27	HK054250040	TERMINAL BASE	FOR 380V			2
28	M1004581000	VENTILATION COVER				1
29	SL4041091SC	SCREW M4 L=10				4
30	HX00147000C	SPACER				4
31	M1005580000	FDD COVER PLATE				1
32	HX004070000	BUSH				1
33	HX004100000	BUSH				1
34	NM3034000SF	FLANGE NUT				4
35	E9608603000	STICKER (MIDDLE)				1
36	S9622710000	MICRO FLOPPY DISC DEVICE				1
37	SL4030681SF	SCREW M3 L=6	FOR 100~200V			4
38	NM3040520SF	FLANGE NUT M4				4
39	SL4040881SF	SCREW M4 L=8				4
40	SL4030891SC	SCREW M3X8				4
41	SL4040681SC	COMBINATION SCREW M4 X 8				2
42	SL4041081SF	SCREW M4 L=10				1
43	SL4041081SF	SCREW M4 L=10	FOR 100~200V			2
44	SM4031851SR	SCREW	FOR 380V			4
45	WS0310702KS	SPRING WASHER	FOR 380V			4
46	SL4041091SC	SCREW M4 L=10				2
47	SL4041091SC	SCREW M4 L=10				6

CONTROL BOX COMPONENTS

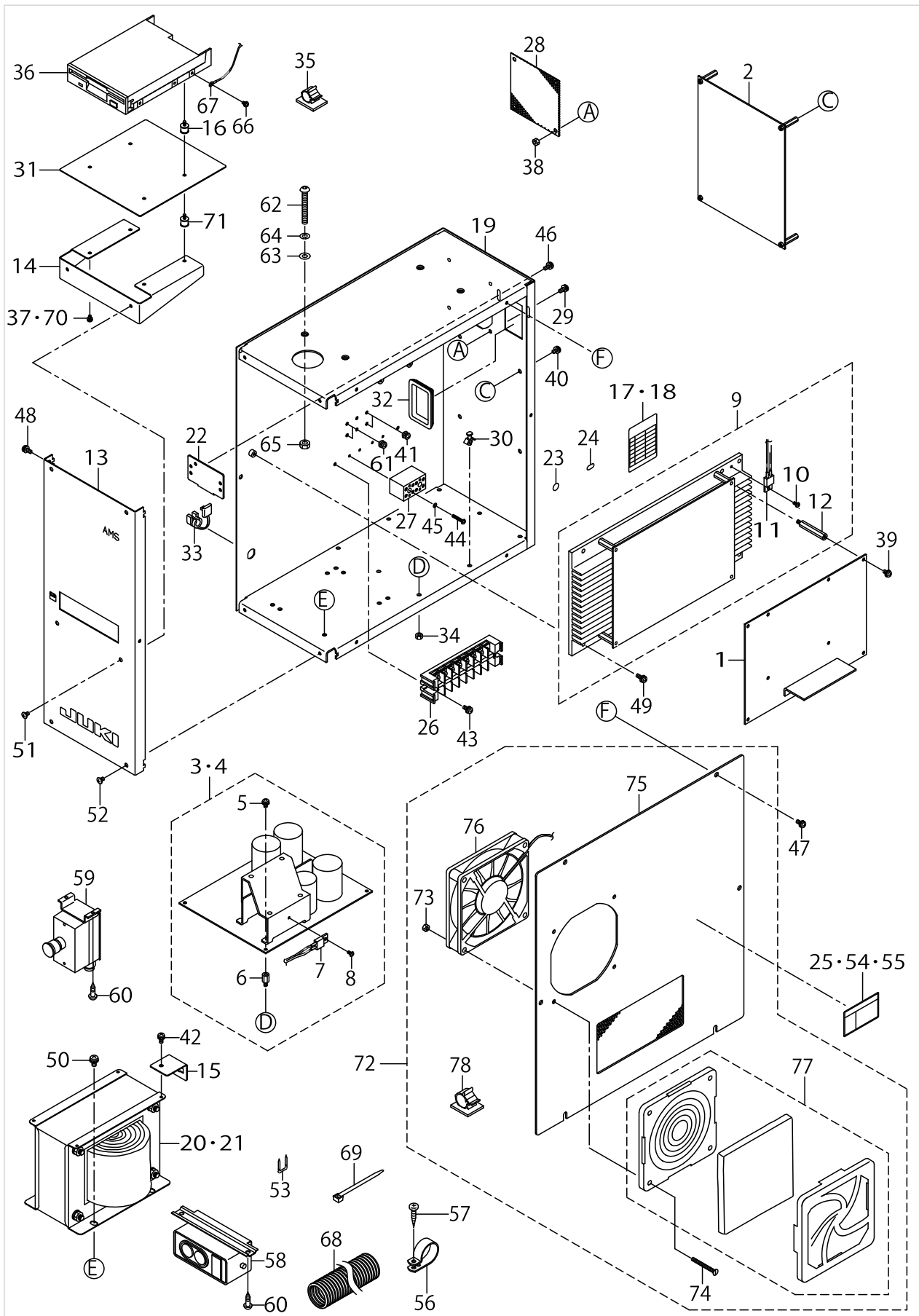

CONTROL BOX COMPONENTS

No.	Parts No.	Parts name	Remarks	Level	Cons	Qty
48	SL4041091SC	SCREW M4 L=10				3
49	SL4041281SF	SCREW M4 L=12				4
50	SL4051081SF	SCREW M5 L=10				4
51	SM0040601SC	SCREW M4X0.7 L=6				2
52	SM0040601SC	SCREW M4X0.7 L=6				4
53	MAO11532000	CORD STAPLE				2
54	CM300100101	DANGER LABEL (SMALL)	FOR 100~200V(USE IN JAPAN)			1
55	G6705152U0A	LABEL	FOR 100~200V(EXPORT)			1
56	HX00150000N	CABLE CLIP				2
57	SK3382001SE	SCREW D=3.8 L=20				2
58	HA004250000	SWITCH	FOR 1-PHASE,3-PHASE(100~200V)			1
59	M85125810A0	SWITCH ASM.	FOR 3-PHASE(380V)			1
60	SK3512001SF	WOOD SCREW				2
61	SL4040681SC	COMBINATION SCREW M4 X 8				2
62	SM3065052TC	SCREW				4
63	WP0651001SC	WASHER				4
64	WS0610002KN	SPRING WASHER 6.1X12.2X1.5				4
65	NM6060001SC	NUT M6				4
66	SL4030681SF	SCREW M3 L=6				1
67	M90295800A0	FDD EARTH CORD ASM.				1
68	HX00307000E	CHUBE				0.3
69	EA9500B0200	CABLE BAND 150				5
70	SL4030681SF	SCREW M3 L=6	FOR 380V			2
71	M2001580000	FDD VIBROISOLATING RUBBER	FOR 380V			4
72	M85115810A0	FAN COVER ASM.				1
73	NM3040520SF	FLANGE NUT M4		*		4
74	SM1044050SM	SCREW M4X0.7 L=40		*		4
75	M10025810A0	CONTROL BOX COVER ASM.		*		1
76	M85105810A0	FAN ASM.		*		1
77	HM000630010	FILTER		*		1
78	E9607603000	STICKER (SMALL)		*		1

WIRING DIAGRAM

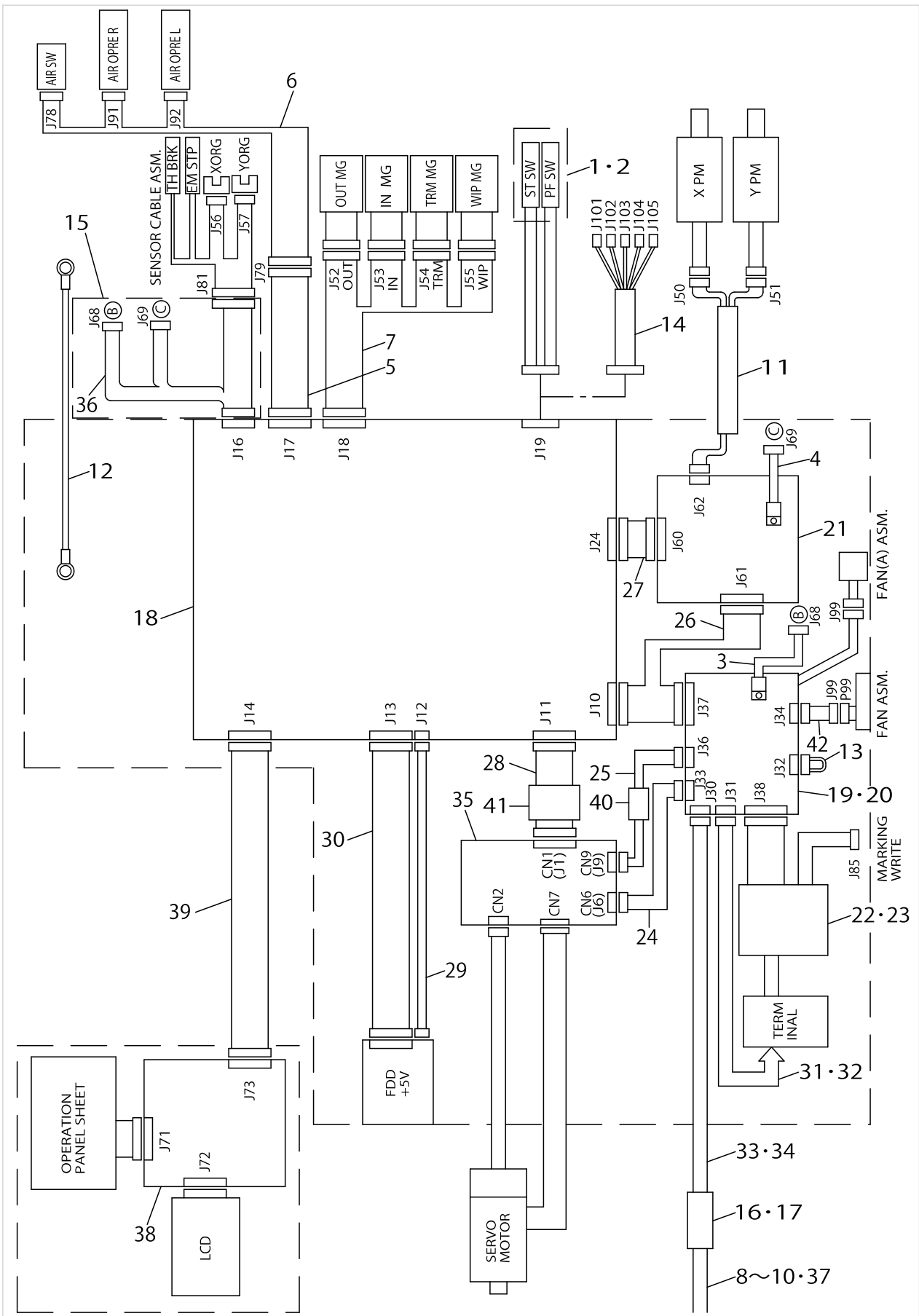

WIRING DIAGRAM

No.	Parts No.	Parts name	Remarks	Level	Cons	Qty
1	M85205800A0	2-PEDAL ASM.	SELECTIVE PARTS			1
2	M85215800A0	3-PEDAL ASM.	SELECTIVE PARTS			1
3	M9012581AA0	THERMAL SWITCH A ASM.				1
4	M90125810A0	THERMAL SWITCH ASM.				1
5	M90145800A0	RELAY CABLE ASM.	FOR 210DSL,DHL			1
6	M90155800A0	SOLENOID VALVE CABLE ASM.	FOR 210DSL,DHL			1
7	M90165800A0	SOLENOID CABLE ASM.				1
8	M90175800A0	POWER CABLE ASM.	FOR 3-PHASE(100~200V)			1
9	M90245800A0	POWER CABLE ASM.,100V	FOR 1-PHASE(100~200V)			1
10	M90145810A0	POWER CABLE ASM.	FOR 3-PHASE(380V)			1
11	M90185800A0	PULSE MOTOR CABLE ASM.				1
12	M90195800A0	EARTH CABLE ASM.				1
13	M90215800A0	VOLTAGE TRANSFER CORD ASM.	FOR 100V			1
14	M90255800A0	PEDAL SW.TRANSFER CABLE ASM.	FOR OPTION PARTS			1
15	40022520	SENSOR RELAY CABLE ASM.				1
16	HA004250000	SWITCH	FOR 1-PHASE,3-PHASE(100~200V)			1
17	M85125810A0	SWITCH ASM.	FOR 3-PHASE(380V)			1
18	M8601580AA0	MAIN CIRCUIT BOARD A ASM.				1
19	M86045800A0	POWER CIRCUIT BOARD ASM.	FOR 100~200V			1
20	M8604580AA0	POWER CIRCUIT BOARD A ASM.	FOR 380V			1
21	M86055800A0	PMDC CIRCUIT BOARD ASM.				1
22	M8901580AA0A	TRANSFORMER A ASM.	FOR 100~200V			1
23	M8901580BA0A	TRANSFORMER B ASM.	FOR 380V			1
24	M90015800A0	SERVO POWER CORD ASM.,A				1
25	M90025800A0	SERVO POWER CORD ASM.,B				1
26	M90055800A0	MP POWER CORD ASM.				1
27	M90075800A0	PMDC SIGNAL CORD ASM.				1
28	M90085800A0	SERVO SIGNAL CORD ASM.				1
29	M90095800A0	FDD POWER CORD ASM.				1
30	M90105800A0	FDD SIGNAL CORD ASM.				1
31	M90205800A0	TRANSFORMER POWER CORD ASM.	FOR 100~200V			1
32	M9020580AA0	TRANSFORMER POWER CORD ASM.,A	FOR 380V			1
33	M90225800A0	POWER CORD ASM.	FOR 100~200V			1
34	M90135810A0	POWER CORD ASM.	FOR 380V			1
35	40022269	SERVO CIRCUIT BOARD ASM.				1
36	M90115810A0	THERMAL SWITCH RELAY CORD ASM.				1
37	M90285800A0	POWER CABLE ASM.	FOR 1-PHASE(380V)			1
38	M86065800A0	OPERATION CIRCUIT BOARD ASM.				1
39	M90125800A0	PANEL SIGNAL CORD ASM.				1
40	HN00149000A	CLAMP FILTER	FOR JE			1
41	HN001490000	CLAMP FILTER(L)	FOR JE			1
42	M90105810A0	FAN CONNECTING CORD ASM.				1

PEDAL & ELECTRICAL EQUIPMENT ACCESSORIE PART COMPONENTS

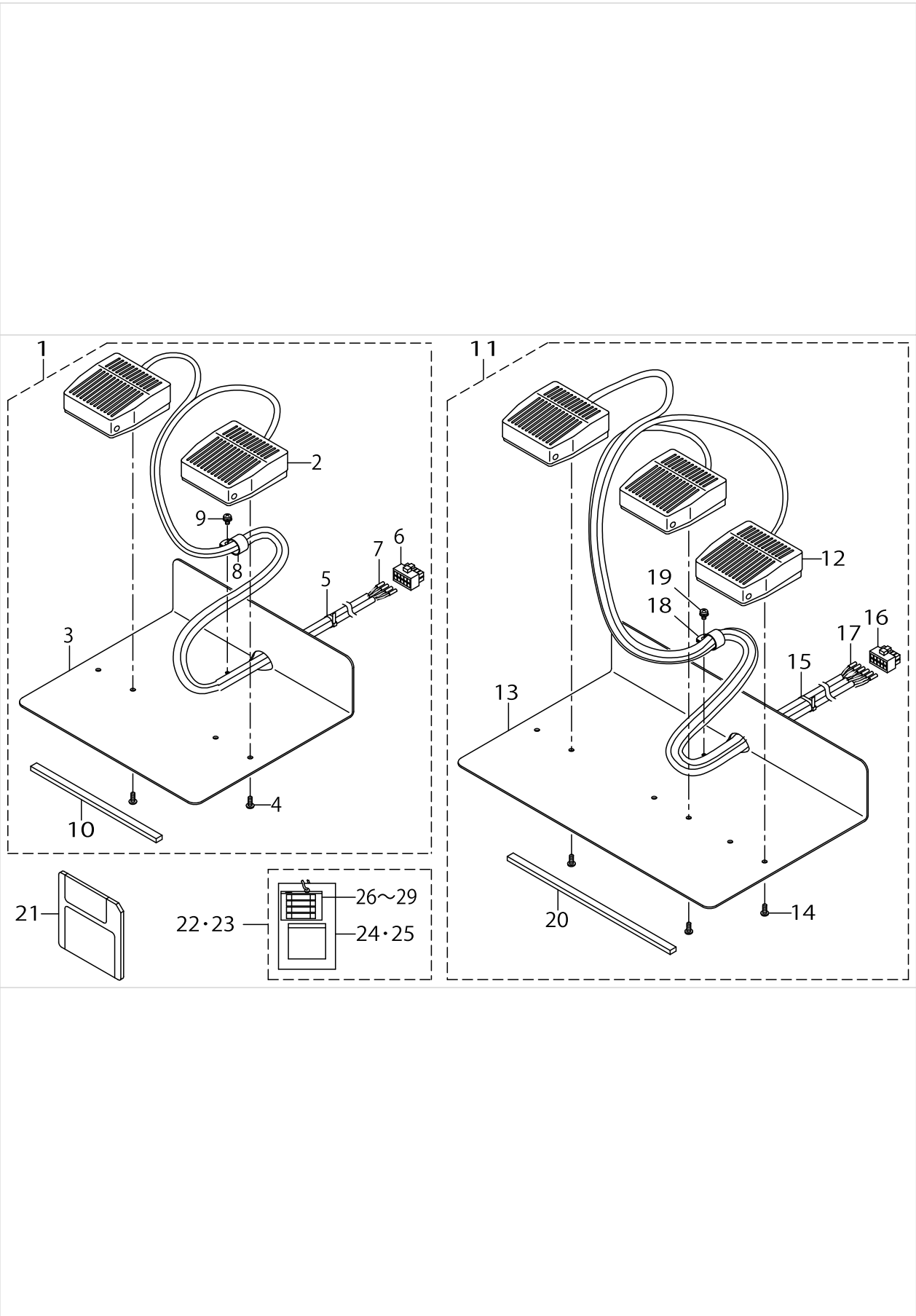

PEDAL & ELECTRICAL EQUIPMENT ACCESSORIE PART COMPONENTS

No.	Parts No.	Parts name	Remarks	Level	Cons	Qty
1	M85205800A0	2-PEDAL ASM.	SELECTIVE PARTS			1
2	HA004260000	FOOT SWITCH		*		2
3	M1012580000	SW. MOUNT PLATE A		*		1
4	ST5041051SN	SCREW		*		4
5	EA9500B0100	CABLE BAND		*		4
6	HK034610100	10P CONNECTOR		*		1
7	HK034640000	PIN CONTACT		*		4
8	EA9502B0500	CABLE CLIP		*		1
9	SL4040881SF	SCREW M4 L=8		*		1
10	GPK26002000	PEDAL BASE RUBBER		*		2
11	M85215800A0	3-PEDAL ASM.	SELECTIVE PARTS			1
12	HA004260000	FOOT SWITCH		*		3
13	M1016580000	SW. MOUNT PLATE,B		*		1
14	ST5041051SN	SCREW		*		6
15	EA9500B0100	CABLE BAND		*		4
16	HK034610100	10P CONNECTOR		*		1
17	HK034640000	PIN CONTACT		*		6
18	EA9502B0500	CABLE CLIP		*		1
19	SL4040881SF	SCREW M4 L=8		*		1
20	GPK26002000	PEDAL BASE RUBBER		*		1
21	M8902580000	FLOPPY DISC				1
22	M85995800A0	ACCESSORIE PART ASM.	FOR 100~200V			1
23	M8599580AA0	ACCESSORIE PART ASM.,A	FOR 380V			1
24	M300451100A	VOLTAGE INDICATION CARD,A	FOR 100~200V	*		1
25	M3003580000	VOLTAGE INDICATION CARD,B	FOR 380V	*		1
26	E9613601000	FUSE 2A		*		1
27	HF004101000	FUSE 10A		*		1
28	E8523304000	FUSE 10A		*		1
29	HF0041050P0	FUSE		*		1

ACCESSORIE PART COMPONENTS

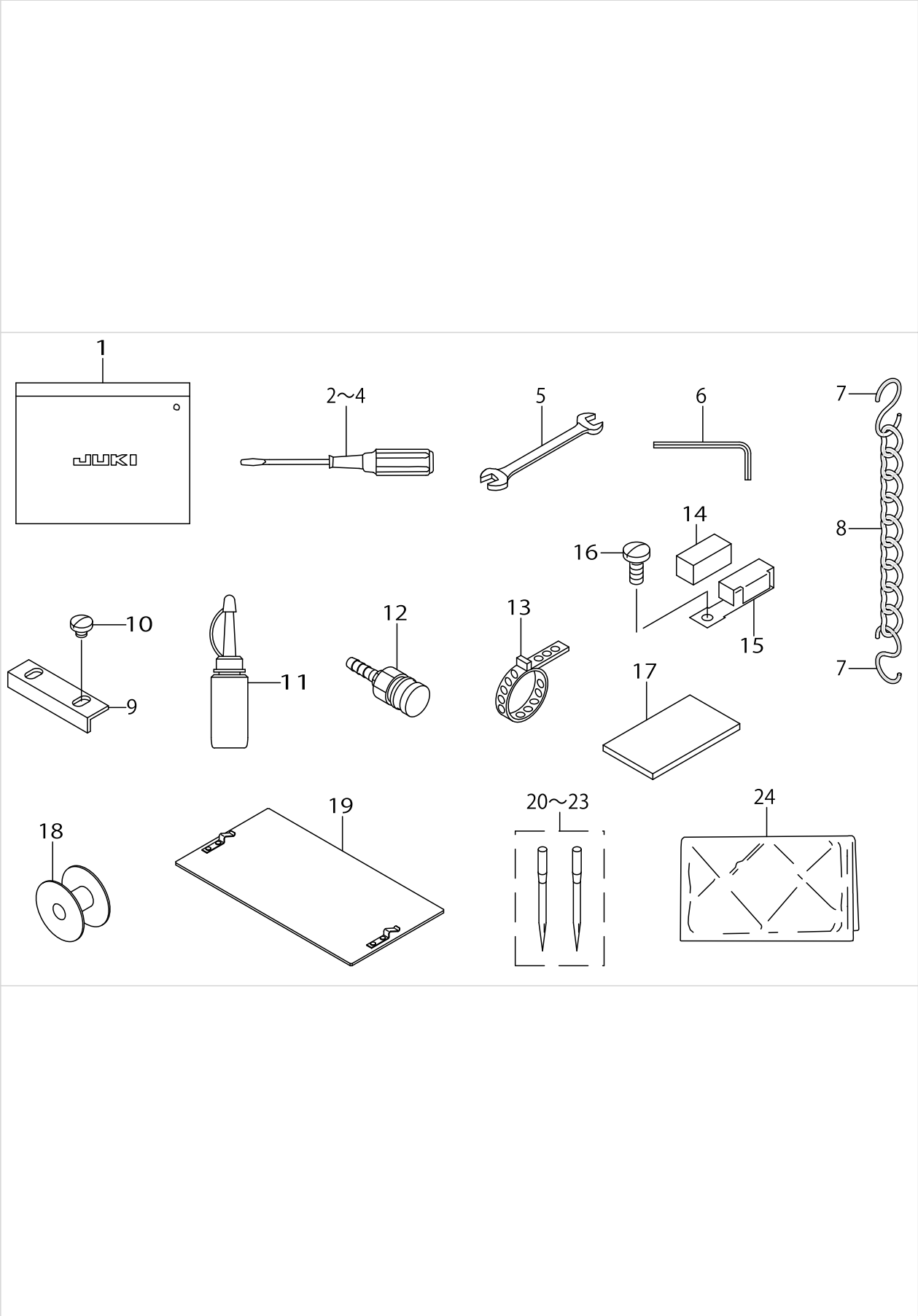

ACCESSORIE PART COMPONENTS

No.	Parts No.	Parts name	Remarks	Level	Cons	Qty
1	B9101552000	ACCESSORY BOX				1
2	B9109555000	SCREW DRIVER, LARGE				1
3	B9110012000	SCREW DRIVER, MIDDLE				1
4	B9111012000	SCREW DRIVER, SMALL				1
5	B9113012000	WRENCH (9X10)				1
6	B9140372000	HEXAGONAL WRENCH, SMALL				1
7	B8133019000	S SHAPED HOOK	FOR 210DSS,DHS			2
8	B8103980000	CHAIN	FOR 210DSS,DHS			1
9	B2592210000	PLASTIC PLATE STOPPER	FOR 210DSS,DHS			1
10	SS7110340SP	SCREW 11/64-40 L= 3.2	FOR 210DSS,DHS			2
11	B91212200A0	OILER (CONTAINING NO.2 OIL)				1
12	PJ309520001	SOCKET	FOR 210DSL,DHL			1
13	PB000010000	HOSE BAND	FOR 210DSL,DHL			1
14	B1131528000	FELT				1
15	10102259	THREAD GUIDE ASM. F				1
16	SS7090910SP	SCREW 9/64-40 L= 8.5				1
17	B2564215000	SPONGE				1
18	B1806210D00	BOBBIN				1
19	B2557210DA0	PLASTIC BLANK PLATE ASM.	FOR 210DSS,DHS			2
20	MDP500B1402	NEEDLE DPX5#14-2	FOR 210DSS,DSL(EXCEPT JE)			1
21	MDP170B1802	NEEDLE DPZ17#18-2	FOR 210DHS,DHL(EXCEPT JE)			1
22	MC200501002	NEEDLE 134 #100-2	FOR 210DSS,DSL(FOR JE)			1
23	MC372001102	NEEDLE SY3355 #110-2	FOR 210DHS,DHL(FOR JE)			1
24	26234005	VINYL COVER				1

OPTIONAL PART COMPONENTS

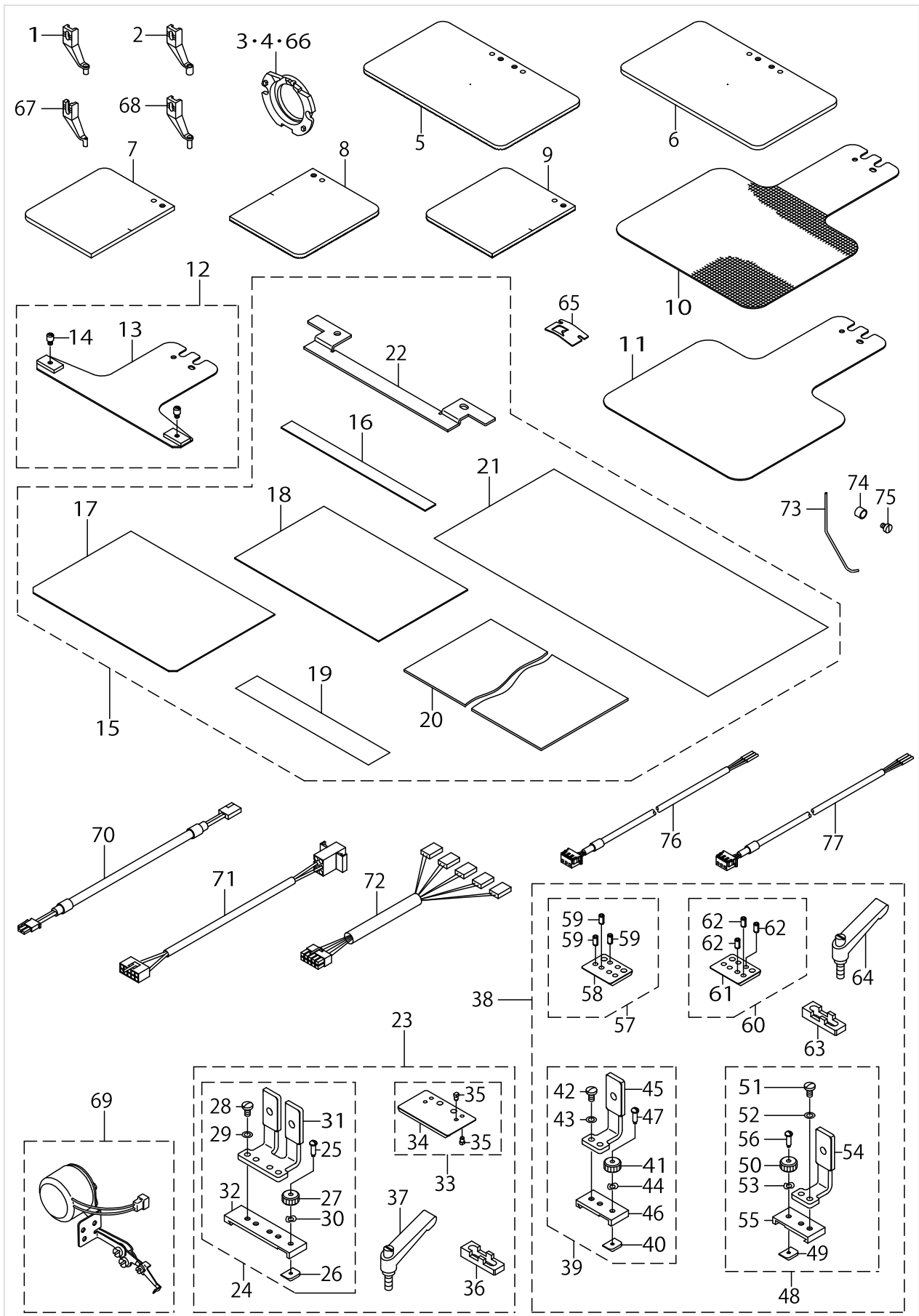

OPTIONAL PART COMPONENTS

No.	Parts No.	Parts name	Remarks	Level	Cons	Qty
1	B1601210D0BA	INTERMEDIATE PRESSER B				1
2	B1601210D0CA	INTERMEDIATE PRESSER C				1
3	B1817210DAC	SHUTTLE RACE RING ASM.,C				1
4	B1817210DAD	SHUTTLE RACE RING ASM.,D				1
5	B2553210D0A	FEEDING FRAME BLANK				1
6	B2553210D0B	FEEDING FRAME BLANK				1
7	B2554210D0A	FEEDING FRAME BLANK				1
8	B2554210D0B	FEEDING FRAME BLANK,RIGHT				1
9	B2554210D0C	FEEDING FRAME BLANK,LEFT				1
10	B2556210D0A	LOWER PLATE BLANK				1
11	B2556210D0B	LOWER PLATE BLANK				1
12	B2593210DA0	CASSETTE HOLDER FIX PLATE ASM.				1
13	B2593210D00	CASSETTE HOLDER FIXING PLATE		*		1
14	B2560372000	BUTTON CLAMP STOP PIN		*		2
15	B2594210DA0	CASSETTE PRESSER ASM.				1
16	B2589210D00	CASSETTE PRESSER SPACER		*		1
17	B2598210D00	CASSETTE PRESSER LOWER PLATE		*		1
18	B2599210D00	CASSETTE PRESSER UPPER PLATE		*		1
19	B2572229000	FILAMENT TAPE		*		1
20	B2587210000	MATERIAL PLATE A		*		1
21	B2646215000	TAPE		*		1
22	B2594210D00	CASSETTE PRESSER BASE PLATE		*		1
23	B2585210DB0	ONE-TOUCH CLAMP ASM.	FOR 210DSS,DHS			1
24	B2585210DA0	SLIDING PLATE ASM.		*		1
25	B5038206000	SET SC		*		1
26	B5039206000	SET PLATE		*		1
27	16108300	NUT B		*		1
28	SS7110840SP	SCREW 11/64-40 L=7.8		*		2
29	WP0480856SP	WASHER 4.8X8.4X0.8		*		2
30	WZ0430200KH	WAVED WASHER		*		1
31	B2585210D00	SLIDING PLATE		*		1
32	B2587210D00	SLIDER HOLDING		*		1
33	B2595210DA0	SLIDER ASM.		*		1
34	B2595210D00	SLIDER		*		1
35	B1816280000	GUIDE PIN		*		4
36	B2597210D00	CLAMP PLATE		*		1
37	B5115210000	FEEDING FRAME CLAMP LEVER		*		2
38	B2586210DB0	ONE-TOUCH CLAMP ASM.	FOR 210DSL,DHL			1
39	B2586210DA0	SLIDING PLATE ASM., RIGHT		*		1
40	B5039206000	SET PLATE		*		1
41	16108300	NUT B		*		1
42	SS7110840SP	SCREW 11/64-40 L=7.8		*		2
43	WP0480856SP	WASHER 4.8X8.4X0.8		*		2
44	WZ0430200KH	WAVED WASHER		*		1
45	B2586210D00	SLIDING PLATE		*		1
46	B2588210D00	SLIDER HOLDING		*		1
47	B5038206000	SET SC		*		1

OPTIONAL PART COMPONENTS

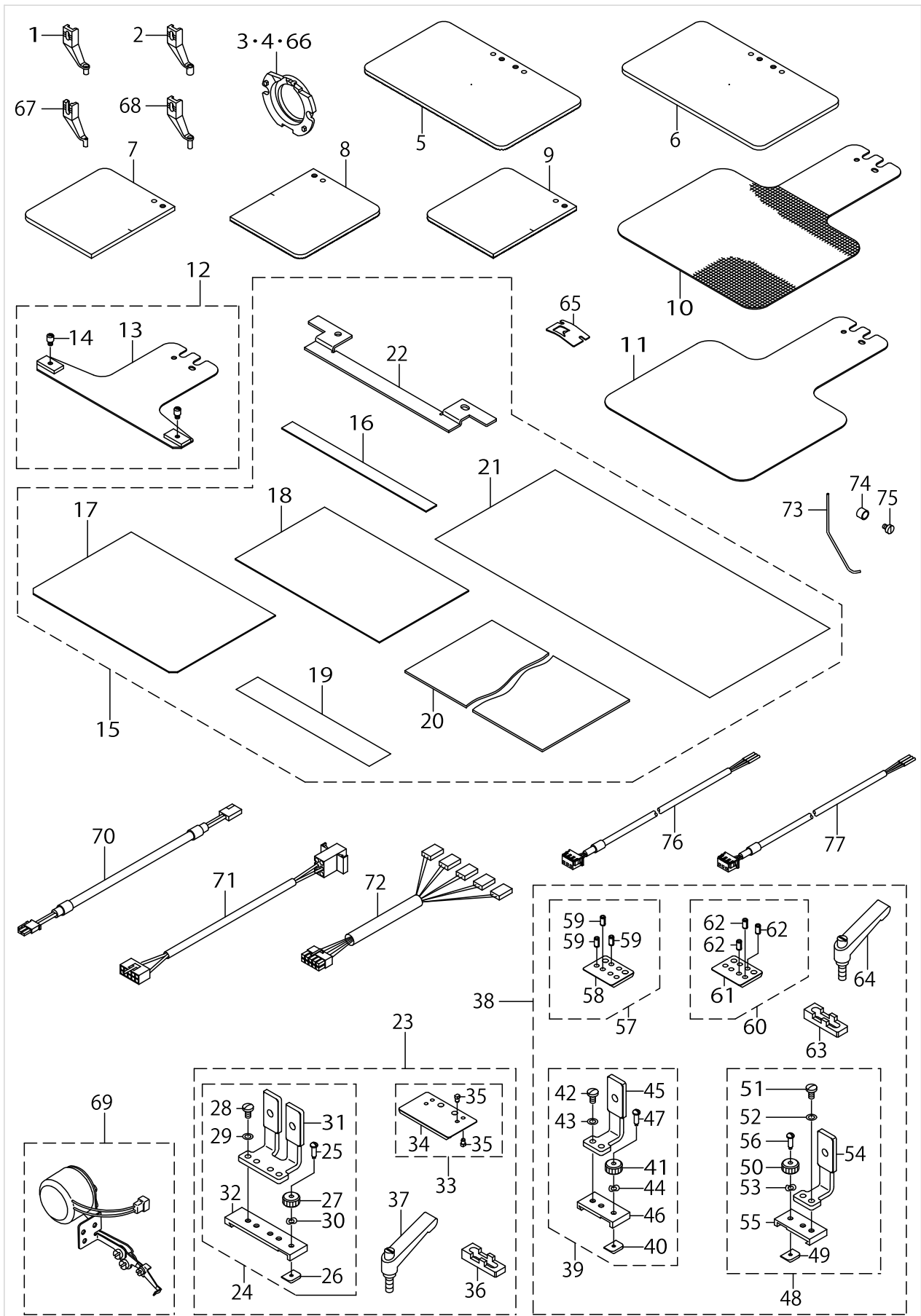

OPTIONAL PART COMPONENTS

No.	Parts No.	Parts name	Remarks	Level	Cons	Qty
48	B2586210DAA	SLIDING PLATE ASM., LEFT		*		1
49	B5039206000	SET PLATE		*		1
50	16108300	NUT B		*		1
51	SS7110840SP	SCREW 11/64-40 L=7.8		*		2
52	WP0480856SP	WASHER 4.8X8.4X0.8		*		2
53	WZ0430200KH	WAVED WASHER		*		1
54	B2586210D00	SLIDING PLATE		*		1
55	B2588210D00	SLIDER HOLDING		*		1
56	B5038206000	SET SC		*		1
57	B2596210DA0	SLIDER ASM., RIGHT		*		1
58	B2596210D00	SLIDER		*		1
59	PS0400082KP	SPRING PIN		*		3
60	B2596210DAA	SLIDER ASM., LEFT		*		1
61	B2596210D00	SLIDER		*		1
62	PS0400082KP	SPRING PIN		*		3
63	B2597210D00	CLAMP PLATE		*		1
64	B5115210000	FEEDING FRAME CLAMP LEVER		*		2
65	B1815210D00	SHUTTLE UPPER SPRING				1
66	B1817210DAA	SHUTTLE RACE RING COMPL.,A				1
67	B1601210D0E	INNER PRESSER E				1
68	B1601210D0FA	INTERMEDIATE PRESSER F				1
69	B21012200A0	WIPER ASM.				1
70	B4150210DA0	WIPER RELAY CABLE ASM.				1
71	M90315800A0	2-PEDAL CONNECTING CORD ASM.				1
72	M90255800A0	PEDAL SW.TRANSFER CABLE ASM.				1
73	B2107210D0B	WIPER				1
74	22956809	BRACKET INSTALLING COLLAR				1
75	SS6090540SP	SCREW 9/64-40 L= 5.0				1
76	B4131210DA0	UPPER SHAFT SENSOR CABLE ASM.				1
77	B4132210DA0	Y SENSOR CABLE ASM.				1

ASM-210D PERFECT STITCH EXCLUSIVE PART COMPONENTS

(Caution) Please understand that the standard stitch specifications of the current AMS-210D cannot be modified to the perfect stitch specifications of the AMS-210D.

(注) 現行のAMS-210D標準ステッチ仕様からAMS-210Dパーフェクトステッチ仕様へ改造による仕様変更はできません。ご了承ください。

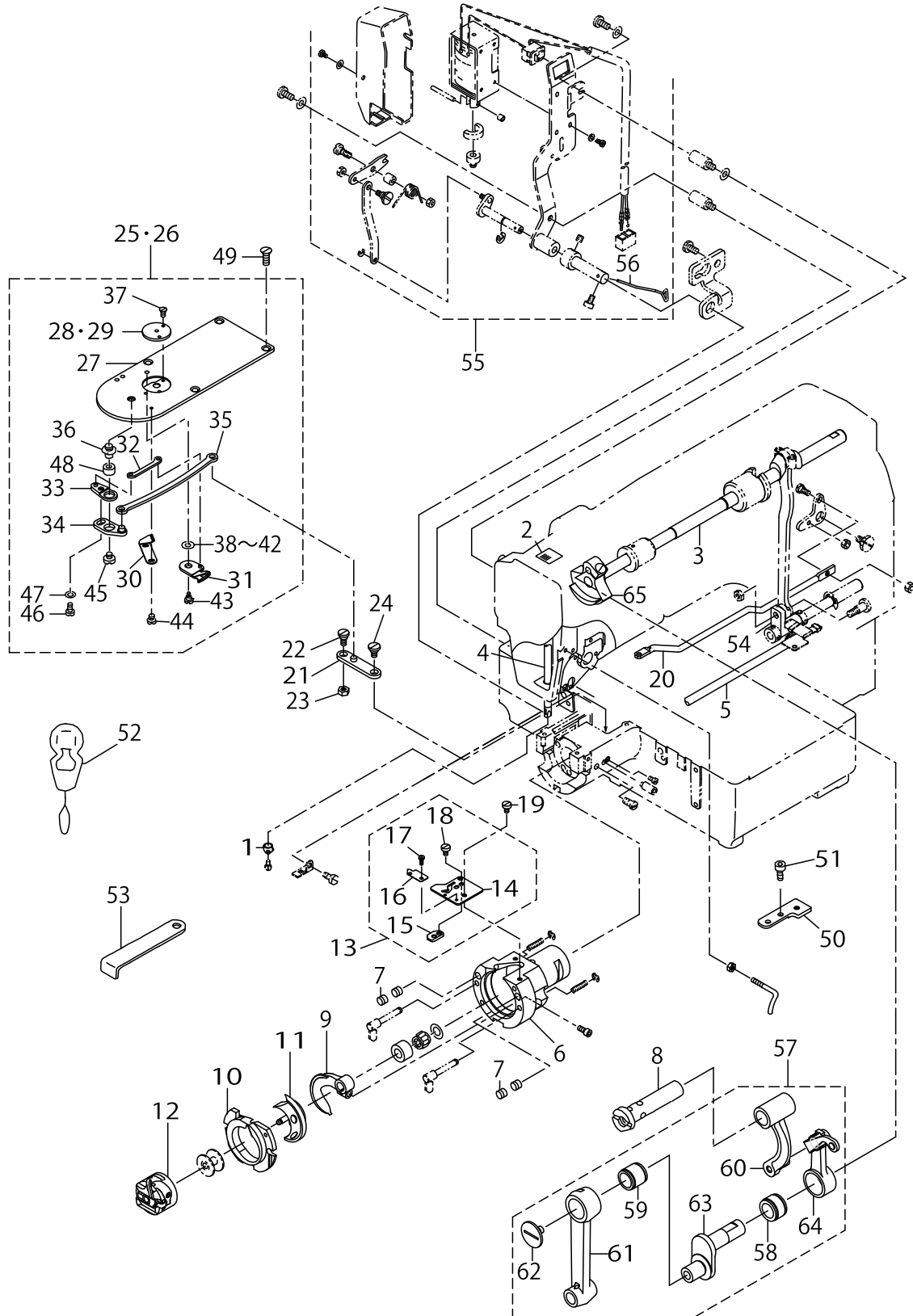

ASM-210D PERFECT STITCH EXCLUSIVE PART COMPONENTS

No.	Parts No.	Parts name	Remarks	Level	Cons	Qty
1	B1406215P00	THREAD GUIDE H				1
2	B1191215P00	NEEDLE SETTING LABEL				1
3	B1201210D0A	P UPPER SHAFT				1
4	B1401210D00	NEEDLE BAR,TYPE P				1
5	B1811210DAA	P LOWER SHAFT GEAR JUNCTION				1
6	B1814215P00	SHUTTLE				1
7	B1226552000	ROLLER FELT				4
8	B1904280000	BALANCE CRANK PIN				1
9	B1812215P00	SHUTTLE DRIVER				1
10	B1854210DA0	P INNER HOOK PRESSER JUMCTION				1
11	B1818215P00	SHUTTLE				1
12	B1852210DA0	P BOBBIN CASE ASM.				1
13	B1816210DA0	UPPER SPRING ASM.				1
14	B1816210D00	SHUTTLE UPPER SPRING, P TYPE		*		1
15	B1840210D00	LOOP RECEIVING PLATE		*		1
16	B1841210D00	LOWER THREAD HOLDER		*		1
17	SS6060220SP	SCREW 3/32-56 L= 2.0		*		2
18	SS6090420SP	SCREW 9/64-40 L= 4.0		*		2
19	SS6090420SP	SCREW 9/64-40 L= 4.0		*		2
20	B2430210D00	THREAD CUTTING CONNECTING BAR				1
21	B2430215PA0	CONNECTING ARM ASM.				1
22	SD0640326TP	HINGE SCREW				1
23	NS6110310SP	NUT 11/64-40				1
24	SD0640326TP	HINGE SCREW				1
25	B2425210PA0	NEEDLE PLATE ASM.				1
26	B2425210PAB	NEEDLE PLATE ASM., H	FOR HEAVY-WEIGHT MATERIAL			1
27	B2425210P00	NEEDLE PLATE		*		1
28	B2426215P0A	NEEDLE HOLE GUIDE D=1.6		*		1
29	B2426215P0B	NEEDLE HOLE GUIDE D=2.0	FOR HEAVY-WEIGHT MATERIAL	*		1
30	B2424215P00	COUNTER KNIFE		*		1
31	B2421215PA0	MOVING KNIFE ASM.		*		1
32	B2418215P00	MOVING KNIFE LINK		*		1
33	B2415215PA0	TRIMMING LEVER ASM. (SMALL)		*		1
34	B2414215PA0	MOVING KNIFE DRIVING LEVER ASM		*		1
35	B2432215P00	THREAD TRIMMING ROD		*		1
36	B2417280000	THREAD CUTTER LEVER SHAFT		*		1
37	SS1060210TP	SCREW 3/32-56 L=2.2		*		2
38	B242328000C	MOVING KNIFE WASHER C	SELECTIVE PARTS	*		1
39	B242328000D	MOVING KNIFE WASHER D	SELECTIVE PARTS	*		1
40	B242328000E	MOVING KNIFE WASHER E	SELECTIVE PARTS	*		1
41	B242328000F	MOVING KNIFE WASHER F	SELECTIVE PARTS	*		1
42	B242328000G	MOVING KNIFE WASHER G	SELECTIVE PARTS	*		1
43	B2417210000	MOVING KNIFE HINGE SCREW		*		1
44	SS7060310SP	SCREW 3/32-56 L=3		*		2
45	SS6110430TP	SCREW 11/64-40 L= 4.0		*		1
46	SS7110740TP	SCREW 11/64-40 L=7		*		1
47	WP0450846SP	WASHER		*		1

ASM-210D PERFECT STITCH EXCLUSIVE PART COMPONENTS

(Caution) Please understand that the standard stitch specifications of the current AMS-210D cannot be modified to the perfect stitch specifications of the AMS-210D.

(注) 現行のAMS-210D標準ステッチ仕様からAMS-210Dパーフェクトステッチ仕様へ改造による仕様変更はできません。ご了承ください。

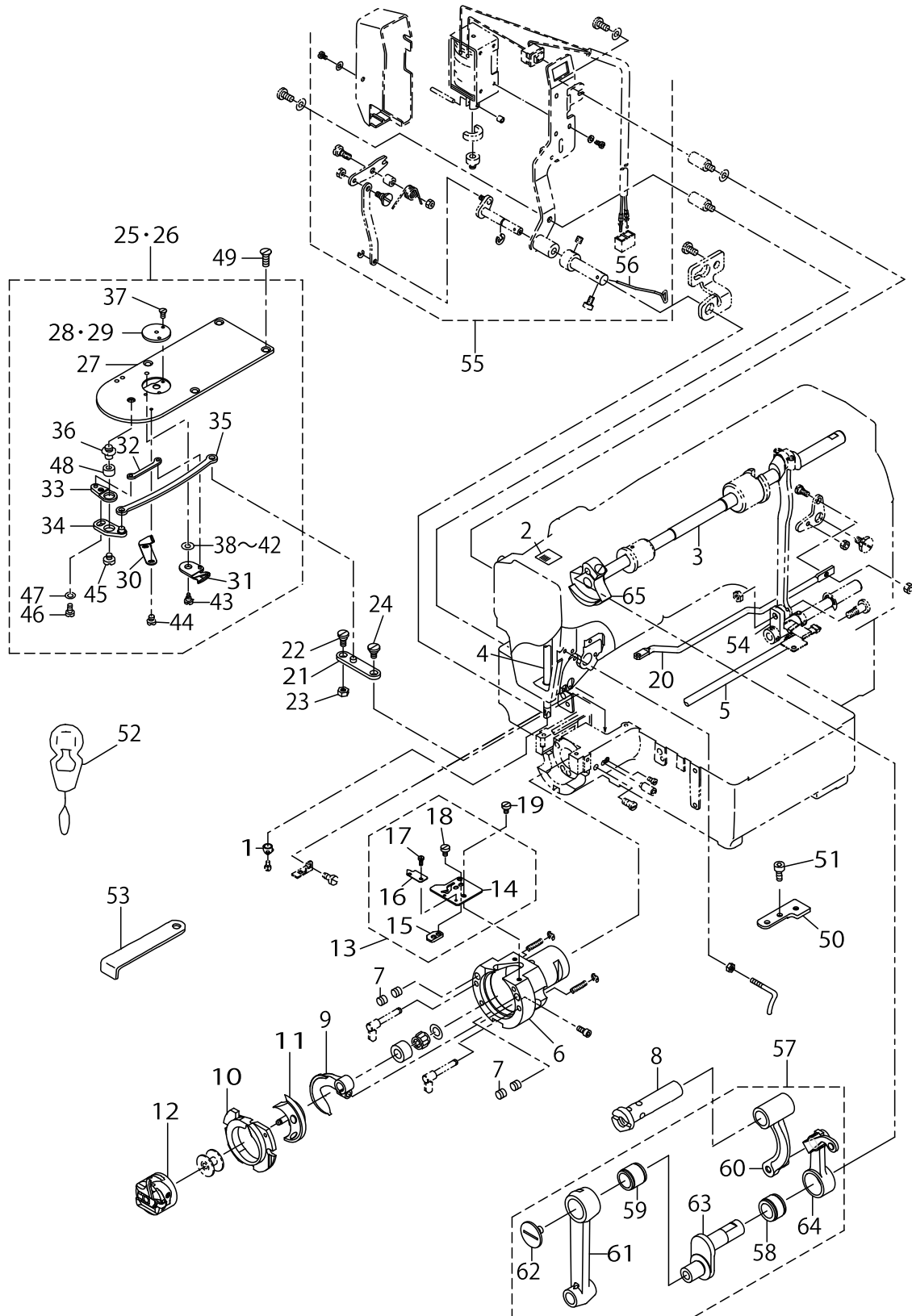

ASM-210D PERFECT STITCH EXCLUSIVE PART COMPONENTS

No.	Parts No.	Parts name	Remarks	Level	Cons	Qty
48	B2416280000	THREAD CUTTING LEVER RING		*		1
49	SS1110640TP	SCREW 11/64-40 L= 5.5				4
50	B2431215P00A	THREAD CONNECTION PLATE				1
51	SS6111052TP	SCREW				2
52	B9107761000	THREAD PASSING INSTRUMENT				1
53	B9101490000	DRIVER				1
54	B1805210D0A	P LOWER SHAFT OSCILLATOR				1
55	B2107210DAA	P WIPER ASM.				1
56	B2107210D0A	P WIPER		*		1
57	B19012800B0	LINK BALANCE ASM.				1
58	B1905541000	NEEDLE BUSHING		*		1
59	B1411804000	NEEDLE DRIVING LEVER BEARING		*		1
60	B1903280000	THREAD TAKE-UP CRANK		*		1
61	B1404280000	NEEDLE BAR CRANK ROD		*		1
62	B1903552000	LEFT SCREW		*		1
63	B1203280000	NEEDLE ROD CRANK		*		1
64	B1901280000	THREAD TAKE-UP LEVER		*		1
65	B1206210000	COUNTERWEIGHT				1

LIST FOR INFORMATION OF CHANGE

As to the place changed, refer to the corresponding Rev.No.
 When previous parts(Obsoleted part)and new parts(Added parts)are
 not interchangeable with each other:
 In this case,even obsoleted parts(D.)can be ordered with the
 obsoleted part number,so select the parts with changed dates and
 place your orders.

変更箇所は,該当Rev.No.版をご参照ください。
 部品の互換性がない変更の場合は,削除された品番でも,ご注文できます。

29289006
 No.1159-07 Rev.No.

*A:Added parts追加部品/D:Obsoleted parts削除部品/E:Erratum訂正

* Rev. No.	Page 頁	Ref. No.	Parts No. 品番	*	Rev. No.	Page 頁	Ref. No.	Parts No. 品番
D 06	2	79	HX-0015000-OJ		A 07	2	79	HX-0015000-OK
D 06	6	23	SS-6121210-SP		A 07	6	23	SS-6121610-SP
					A 07	12	19	135-29607
D 06	13	5	111-10152		A 07	13	5	400-34676
D 06	34	68	HX-0030700-00		A 07	34	68	HX-0030700-0E
D 06	38	8	B8131-019-000		A 07	38	8	B8103-980-000
					A 07	38	24	262-34005

HOW TO MAKE USE OF THIS PARTS LIST

1.Explanation of codes

1)"*"mark.....means this part is changed from the previous parts book.

As to the details of the change, refer to the "List for information of change".

2)"#01".....refer to "Note" explanation at bottom of page.

2.Codes on the "Qty" column

- Each numeral indicates the number of parts required.
- "0.1" and "2.5" indicate the length (in meters) of the respective parts.

3.Parentheses mean that the corresponding part is a subpart that constructs an assembly part.

4.Dotted lines on the Figures indicate assembly parts.

1."注記"欄の記号説明

1) "*"印.....前回のパーツブックに比較して今回変更された部品を意味します。

変更内容は、"変更情報リスト"を参照してください。

2) "#01".....ページ下の"注記"の説明を参照してください。

2.数量欄の数字は、個数を表し、0.1、2.5等の数値は、長さ（単位メートル）を表します。

3.数量欄の（ ）は、組部品を構成している子部品であることを意味します。

4.イラストページの-----枠は、組構成であることを意味します。

NUMERICAL INDEX OF PARTS

PART NO	PAGE	REF NO.	PART NO	PAGE	REF NO.	PART NO	PAGE	REF NO.
10004109	2	31	22538300	2	25	40022269	54	2
10102259	62	15	22538409	2	15	40022269	58	35
10502300	2	28	22907208	18	21	40022327	12	58
10523504	22	31	22907505	18	25	40022507	4	81
10618304	2	16	22907554	18	23	40022517	10	5
11010303	18	22	22907604	18	24	40022520	58	15
11047107	2	29	22920508	2	41	40034676	26	5
11072402	2	33	22924005	16	49	A1230500000A	10	17
11110301	26	6	22930309	50	14	A321600100A	2	22
11111051	26	13	22930358	50	1	B1104210D00	2	4
11155108	48	25	22930408	50	10	B1105210D00	2	5
11155207	48	26	22930507	50	9	B1106210D00	8	1
11158300	48	3	22930705	50	7	B1107210D00	2	1
11158409	48	4	22930804	50	5	B1108210D00	8	5
11158516	48	5	22930903	50	4	B1109210DA0	8	3
11158607	48	6	22931000	50	3	B1110210DA0	8	6
11159001	48	13	22931109	50	2	B1111210D00	2	2
11217114	10	15	22931208	50	15	B1111232000	2	38
11217213	10	14	22931307	50	11	B1112210D00	8	2
11847308	18	26	22931406	50	8	B1113210D00	8	8
12210803	16	56	22955504	26	4	B1113223C00	8	9
12284303	18	33	22955900	26	7	B1115210D00	2	3
13508403	22	33	22956007	26	8	B1115232000	30	6
13508700	22	34	22956106	26	9	B11152320A0	30	3
13513205	28	5	22956205	26	10	B1116210D00	2	9
13513304	28	6	22956403	26	12	B1116804000	30	47
13518105	34	25	22956809	66	74	B1117210D00	2	7
13518105	38	15	22956908	26	14	B1118210DA0	8	7
13529607	22	19	22957104	26	15	B1121210D00	2	6
13551254	4	87	22957203	26	16	B1122210D00	2	8
13716808	28	7	23604309	10	3	B1123210000	8	10
13717707	20	83	26211607	2	30	B1123210D00	2	10
13722509	18	28	26221101	22	35	B1123280000	2	39
13816855	22	37	26221200	22	36	B1124210000	8	11
13817408	28	16·22	26222208	24	49	B1125210D00	2	11
14107809	30	2	26226001	20	76	B1125215P00	2	40
14113450	2	36	26230706	46	9	B1126210000	6	97
14113468	2	32	26231100	22	10	B1129210000	2	42
16108300	64	50	26234005	62	24	B1131528000	62	14
16108300	66	50	26500900	28	3	B1143210000	4	93
17007402	48	7	26501858	22	16	B1144210000	10	19
17700402	26	34	26502906	18	31	B1148555000	2	21
17845009	54	22	40022157	52	7~9	B1178191000	2	43
22537658	2	14	40022182	52	4~6	B1181210D00	8	4
22538151	2	20	40022185	52	1~3	B1191215P00	68	2

NUMERICAL INDEX OF PARTS

PART NO	PAGE	REF NO.	PART NO	PAGE	REF NO.	PART NO	PAGE	REF NO.
B1201210D00	10	7	B1511210D00	14	16	B1633210D00	18	13
B1201210D0A	68	3	B1513210D00	14	21	B1634210D00	20	71
B1202210000	12	57	B1515210D00	14	23	B1641562000	18	29
B1203210000	10	18	B1516210D00	14	13	B1642210D00	18	14
B1203280000	70	63	B151902600G	34	43	B1649161000	18	35
B1206210000	70	65	B1520210D00A	14	11	B1649161000	28	25
B1206210D00	10	9	B1522210D00	14	14	B1649161000	30	45
B1207210D00	10	6	B1525210D00	14	8	B1652210D00	20	81
B1208210D00	10	8	B1526804000	16	50	B1673180000	20	79
B1212210D00	10	13	B152989000CA	2	18	B1701210000	14	19
B1213210D00	10	1	B1530210D00	14	17	B1701210D00	14	46
B1214210D00	10	2	B1531210D00	16	55	B1702210D00	14	47
B1215210D00	10	11	B1601210D00A	18	1	B1703210D00	16	48
B1216210D00	10	12	B1601210D0BA	64	1	B1802210D00	22	32
B1223771000	10	47	B1601210D0CA	64	2	B1805210D00	22	2
B1226552000	68	7	B1601210D0E	66	67	B1805210D0A	70	54
B1401210A00	10	40	B1601210D0FA	66	68	B1806210D00	22	23
B1401210D00	68	4	B1603210D00	18	3	B1806210D00	62	18
B1402280000	10	41	B1604210D00	18	2	B1808210D00	22	26
B1403280000	10	45	B1605210D00	20	52	B1808980000	22	46
B1404280000	10	38	B1606210D00	18	8	B1811210DA0	24	59
B1404280000	70	61	B1607210D00	18	9	B1811210DAA	68	5
B1405210000	10	42	B1609210D00	18	5	B1812210D00	22	20
B1406210000	10	43	B1610210D00	18	7	B1812215P00	68	9
B1406215P00	68	1	B161121000A	18	32	B1813980000	22	9
B1407210D00	10	33	B1611210D00	18	17	B1814210D00	22	6
B1408180000	18	30	B1612210D00	18	6	B1814210DA0	22	5
B14115520A0	10	46	B1614210D00	18	27	B1814215P00	68	6
B1411804000	10	36	B1615210D00	18	37	B1815210000	24	47·48
B1411804000	70	59	B1619210D00	20	78	B1815210D00	66	65
B1411804A00	22	42~45	B1620210D00	18	10	B1815980000	22	47·48
B1411804B00	22	42~45	B1621210D00A	18	11	B1816210D00	68	14
B1411804C00	22	42~45	B1622210D00	18	12	B1816210DA0	68	13
B1411804D00	22	42~45	B1626210D00	18	41	B1816280000	64	35
B1414232000	10	44	B1626220000	40	35	B1817210DAA	66	3·4·66
B1501210DA0	14	2	B1626220000	42	30	B1817210DAB	22	4
B1502210D00	14	7	B1626555000	40	33	B1817210DAC	64	3·4·66
B1503210DA0	14	3	B1627210D00	18	16	B1817210DAD	64	3·4·66
B1504210D00	14	4	B1628210D0B	14	18	B1818210D0A	22	21·22
B1505210D00	14	5	B1628210D0B	18	20	B1818210D0B	22	21·22
B1506210D00	14	6	B1629210D00A	18	19	B1818215P00	68	11
B1507210D00	14	1	B1629224000	18	34	B1820210D00	22	7
B1508210D00	14	9	B1630210D00	18	4	B1821210D00	22	8
B1509210D00	14	10	B1631210D00	18	18	B1822215P00	22	17
B1510210D00	14	15	B1632210D00	18	15	B1828210D0A	22	25

NUMERICAL INDEX OF PARTS

PART NO	PAGE	REF NO.	PART NO	PAGE	REF NO.	PART NO	PAGE	REF NO.
B1828210DAA	22	24	B2409210D00	30	11	B2440210D00	30	16
B1836210D00	22	1	B2411210000	30	43	B2501210D00	34	2
B1840210D00	68	15	B2412210D00	30	12	B2501210DA0A	34	1
B1841210D00	68	16	B2413210D00	30	18	B2502210D00A	34	3
B1852210DA0	68	12	B2414215PA0	68	34	B2505210D00	34	19
B1854210DA0	68	10	B24142800A0	30	31	B2506210D00	34	22
B1901210DA0	10	32	B2415215PA0	68	33	B2507210D00	34	4
B1901210DC0	10	31	B24152800A0	30	29·30	B2508210DA0	34	5
B1901280000	70	64	B24162100A0	30	29·30	B2509210D00	34	23
B19012800B0	70	57	B2416280000	30	28	B2509210D00	38	10
B1903210000	10	34	B2416280000	70	48	B2509704000	38	14
B1903280000	70	60	B2417210000	30	33	B2510210D00	38	13
B1903552000	10	37	B2417210000	68	43	B2511210D00	38	5
B1903552000	70	62	B2417280000	30	42	B2512210D00A	34	18
B1904280000	10	39	B2417280000	68	36	B2513210D00A	34	16
B1904280000	68	8	B2418215P00	68	32	B2513210D00A	38	2
B1905541000	10	35	B2418280000	30	27	B2514210D00A	34	17
B1905541000	70	58	B2421210AA0	30	26	B2514210D00A	38	3
B21012200A0	66	69	B2421215PA0	68	31	B2518210D00	38	6
B2102816000A	18	36	B242328000A	30	37~40	B2519210D00	34	6
B2107210D00	26	2	B242328000B	30	37~40	B2520210D0A	34	7
B2107210D0A	70	56	B242328000C	30	37~40	B2520210D0B	34	8
B2107210D0B	66	73	B242328000C	68	38~42	B2521210D00	34	9
B2107210DA0	26	1	B242328000D	30	37~40	B2522210D00	34	10
B2107210DAA	70	55	B242328000D	68	38~42	B2523210D00	38	11
B2110210D00	26	33	B242328000E	68	38~42	B2524210D00	38	12
B2111210D00	26	3	B242328000F	68	38~42	B2525205000	38	16
B2130210D00	26	11	B242328000G	68	38~42	B2525210D00	38	8
B2301210D00	30	1	B2424210000	30	25	B2526210D00	34	21
B23022050AA	28	8·9	B2424215P00	68	30	B2527210000	34	11
B2302280000	28	13	B2425210000	30	22	B2528210D00A	38	4
B23022800A0	28	8·9	B2425210DAA	30	20·21	B2529210D00	36	50
B2303205000	30	46	B2425210DAB	30	20·21	B2529210D00	38	1
B2303280000	28	23	B2425210P00	68	27	B2530210D00	34	42
B2304210D00	28	1	B2425210PA0	68	25·26	B2534210D00	34	20
B2305205000	28	11·19	B2425210PAB	68	25·26	B2536210D00A	38	9
B2308210D00	28	2	B242621000A	30	23·24	B2548210D00	38	7
B2312210D00	30	15	B242621000B	30	23·24	B2550210D00	40	1
B2313280000	28	12	B2426215P0A	68	28·29	B2550210D00	42	1
B2315210D00	28	4	B2426215P0B	68	28·29	B2551210DA0A	40	16
B2401210D00	30	14	B2430210D00	68	20	B2552210D00	40	11
B2402210D00	30	10	B2430215PA0	68	21	B2552210D00	42	4
B2404210DA0	30	19	B2431215000	32	48	B2553210D00	40	10
B2407210D00	30	17	B2431215P00A	70	50	B2553210D0A	64	5
B2408210D00	30	13	B2432215P00	68	35	B2553210D0B	64	6

NUMERICAL INDEX OF PARTS

PART NO	PAGE	REF NO.	PART NO	PAGE	REF NO.	PART NO	PAGE	REF NO.
B2554210D00	42	6	B2590210DA0	42	7	B3505210D00	46	1
B2554210D0A	64	7	B2591210DA0	42	8	B3506210D00	46	2
B2554210D0B	64	8	B2592210000	62	9	B3507220000	46	11
B2554210D0C	64	9	B2593210D00	64	13	B3507280000	46	16
B2556210D0A	64	10	B2593210DA0	64	12	B3508280000	46	14
B2556210D0B	64	11	B2594210D00	64	22	B3509210D00	46	3
B2557210DA0	62	19	B2594210DA0	64	15	B3509220000	46	28
B255728000C	40	31	B2595210D00	64	34	B3509280000	46	15
B2560210D00	42	3	B2595210DA0	64	33	B3511210D00A	16	58
B2560372000	64	14	B2596210D00	66	61	B3511210D0AA	16	59
B2561210D00	42	12	B2596210DA0	66	57	B3518280000	46	7
B2562210D00	42	13	B2596210DAA	66	60	B3520220000	46	5
B2564210D00	42	2	B2597210D00	64	63	B35222100A0	46	6
B2564215000	62	17	B2597210D00	66	63	B3523220000	46	10·37
B2566210D00	42	10	B2598210D00	64	17	B3549850000	26	35
B2567210D00	42	11	B2599210D00	64	18	B4004210D00	34	45
B2570210D00	40	2	B2610210D00	40	19	B4007210D00	34	24
B2571210D00	40	3	B2610210D00	42	9	B4008210D00	38	34
B2572210D00	40	12	B2617771000	32	53	B4110210D00A	4	80
B2572210D00	42	5	B2619372000	28	24	B4131210DA0	66	76
B2572229000	64	19	B2646215000	64	21	B4132210DA0	66	77
B2573210D00	40	9	B2702210000	28	40	B4150210DA0	66	70
B2574210D00	40	6	B2703210000	4	82	B47152150A0	44	4
B2575210D00	40	7	B2707761000	2	44	B5038206000	64	56
B2576210D00	40	17	B3107804000	28	15	B5038206000	66	56
B2577210D00	40	4	B3111352000	30	8	B5039206000	64	49
B2578210D00	40	5	B3112761000	28	10·14	B5039206000	66	49
B2579210D00A	40	8	B3114232000	28	11·19	B5115210000	64	64
B2580210D00	40	18	B3114771000	2	45	B5115210000	66	64
B2581210D00	40	14	B3119771000	28	16·22	B8101210AAB	48	8
B2582210D00	40	15	B3120125000	28	17	B8101210DA0	48	1·2
B2583210D00	40	13	B3123352000	30	4	B8101210DAA	48	1·2
B2585210D00	64	31	B3125012000	30	7	B8103980000	62	8
B2585210DA0	64	24	B3126012000	2	35	B8105210AAA	48	9
B2585210DB0	64	23	B3126012000	28	18	B8110221D00	48	24
B2586210D00	64	54	B3126012000	30	5	B8133019000	62	7
B2586210D00	66	54	B3132552000	28	20	B8150210000	48	10
B2586210DA0	64	39	B3204210DA0	2	13	B8153771000	48	16
B2586210DAA	66	48	B3204210DB0	2	12	B8201210D00A	48	23
B2586210DB0	64	38	B3205210000	2	19	B8202205000	48	27
B2587210000	64	20	B3212761000	2	23	B8203205000A	48	28
B2587210D00	64	32	B3213205000	10	29	B8210012000	48	29
B2588210D00	64	55	B3501210000	2	46	B8211206000	44	15
B2588210D00	66	55	B3502220000	46	32	B8267180000	2	47
B2589210D00	64	16	B3504280000	22	11	B8404352000	18	38

NUMERICAL INDEX OF PARTS

PART NO	PAGE	REF NO.	PART NO	PAGE	REF NO.	PART NO	PAGE	REF NO.
B9101490000	70	53	D2588L8WB00	32	50	HK034640000	60	17
B9101552000	62	1	D3112L4BB00	28	10·14	HK03464000B	26	18
B9107761000	70	52	D3310555D00	14	20	HK054250040	54	27
B9109555000	62	2~4	D7133555B00	2	34	HM000630010	56	77
B9110012000	62	2~4	D8113555B00	48	17	HN001490000	58	41
B9111012000	62	2~4	D8204555D00	48	30	HN00149000A	58	40
B9113012000	62	5	E2650453000	36	49	HW200390000	26	20
B9121012000	48	31	E2651453000	38	39	HW500070000	26	21
B91212200A0	62	11	E8523304000	60	26~29	HX00056000B	54	6
B9140372000	62	6	E9567319000	54	23	HX00123000A	4	83
BP300000000	22	15	E9607603000	56	78	HX00147000C	54	30
BP300000000	46	45·46	E9608603000	54	35	HX00150000K	4	79
BP600000000	46	10·37	E9613601000	60	26~29	HX00150000N	56	56
BT0400251EB	42	33	EA9500B0100	6	96	HX00223000A	16	54
BT0600401EB	44	16	EA9500B0100	44	14	HX00307000E	56	68
CM200100001	54	24	EA9500B0100	46	8	HX00339000D	54	12
CM300100001	54	25·54·55	EA9500B0100	60	15	HX004070000	54	32
CM300100101	56	25·54·55	EA9500B0200	56	69	HX004100000	54	33
CM300200002	4	91·92	EA9502B0500	60	18	M1001590000	54	19
CM3002000B2	4	91·92	G1216870000	10	10	M10025810A0	56	75
CM300200301	4	89·90	G5126172000	42	32	M1003580000	54	13
CM3002003A1	4	89·90	G6705152U0A	56	25·54·55	M1004581000	54	28
CM500100001	48	41	G8124270000	44	5	M1005580000	54	31
CQ200000000	46	45·46	GAF01007000	10	20	M1006580000	54	14
CQ202000000	46	33·34	GPF06060000	48	18	M1011580000	52	18
CQ252200000	22	14	GPF06070000	48	19	M1012580000	60	3
CQ252200000	46	43·44	GPF06080000	48	14	M1014580000	54	15
CS0700811SH	20	73	GPK26002000	60	20	M1016580000	60	13
CS079073ASH	18	42	HA000590000	26	19	M1017580000A	52	22
CS079073ASH	40	36	HA004250000	56	58	M10175800A0	52	21
CS079073ASH	42	34	HA004250000	58	16·17	M1019580000	52	23
CS080081CSH	24	52	HA004260000	60	12	M1030580000A	52	10
CS080081CSH	30	54	HD00057000A	34	46	M10305800A0	52	4~6
CS080081CSH	32	54	HD002230000	38	35	M10305800B0	52	4~6
CS1000811SP	24	50	HF004101000	60	26~29	M1031580000	52	17
CS1201010SH	22	3	HF0041050P0	60	26~29	M10315800A0	52	16
CS147121ESH	10	21	HK026650080	54	26	M1032580000	52	11
CS1701011SZ	14	24	HK034610020	26	17	M2001580000	54	71
D1510491D00	18	40	HK03461002D	14	45	M2001580000	56	71
D2112555B00	46	17	HK03461002E	18	39	M300258000B	54	17·18
D2431555B00	28	26	HK034610040	44	11	M3003580000	60	24·25
D2468555B00	14	22	HK034610100	60	16	M300451100A	60	24·25
D2502232D00	40	34	HK034620020	32	52	M300551100A	54	17·18
D2502232D00	42	31	HK034630000	32	51	M300558000AA	52	7~9
D2587L8WB00	32	49	HK034640000	44	6	M300558000BA	52	7~9

NUMERICAL INDEX OF PARTS

PART NO	PAGE	REF NO.	PART NO	PAGE	REF NO.	PART NO	PAGE	REF NO.
M8510580AA0	52	1~3	M90145810A0	58	8~10-37	NM6160511SE	50	18
M8510580BA0	52	1~3	M90155800A0	58	6	NS6090310SP	4	50
M85105810A0	56	76	M90165800A0	58	7	NS6090310SP	26	23
M85115810A0	56	72	M90175800A0	58	8~10-37	NS6110310SP	2	37
M85125810A0	56	59	M90185800A0	58	11	NS6110310SP	18	43
M85125810A0	58	16-17	M90195800A0	58	12	NS6110310SP	26	24
M85205800A0	58	1-2	M90205800A0	58	31-32	NS6110310SP	28	27
M85205800A0	60	1	M90205800AA0	58	31-32	NS6110310SP	68	23
M85215800A0	58	1-2	M90215800A0	58	13	NS6110420SP	32	58
M85215800A0	60	11	M90225800A0	58	33-34	NS6120310SP	28	41
M85415800A0	52	13	M90245800A0	58	8~10-37	NS6120630SP	32	59
M85995800A0	60	22-23	M90255800A0	58	14	NS6150310SP	4	51
M8599580AA0	60	22-23	M90255800A0	66	72	NS6150310SP	30	9
M8601580AA0	54	1	M90285800A0	58	8~10-37	NS6620310SP	18	44
M8601580AA0	58	18	M90295800A0	56	67	NS6660430SP	24	53
M86045800A0	58	19-20	M90315800A0	66	71	PA1602006A0	42	35
M8604580AA0	58	19-20	M964051000A	48	42	PB000010000	62	13
M86045900B0A	54	3-4	MAO11108N00	48	34	PC010507000	44	2
M8604590AB0A	54	3-4	MAO11532000	56	53	PF0552040B0	44	8
M86055800A0	58	21	MC200501000	12	53~56	PH0500322C0	14	25
M86055800A0A	54	9	MC200501002	62	20~23	PJ046052503	42	36
M86065800A0	52	14	MC372001100	12	53~56	PJ304065101	44	3
M86065800A0	58	38	MC372001102	62	20~23	PJ305065202	44	10
M8901580AA0A	54	20-21	MDP170B1800	12	53~56	PJ309520001	62	12
M8901580AA0A	58	22-23	MDP170B1802	62	20~23	PS0150042K0	8	12
M8901580BA0A	54	20-21	MDP500B1400	12	53~56	PS0400082KP	66	62
M8901580BA0A	58	22-23	MDP500B1402	62	20~23	PS0400142KH	10	16
M8902580000	60	21	NM3034000SF	54	34	PV0351130A0	44	1
M90015800A0	58	24	NM3040520SF	54	73	PX950009000	44	7
M90025800A0	58	25	NM3040520SF	56	73	RC0470611KP	18	45
M90055800A0	58	26	NM6040003SC	32	55	RC0560711KP	2	27
M90075800A0	58	27	NM6050001SD	16	51	RE0250000K0	26	25
M90085800A0	58	28	NM6050001SE	50	17	RE0300000K0	22	18
M90095800A0	58	29	NM6050001SP	32	56	RE0300000K0	40	38
M90105800A0	58	30	NM6050001SP	34	26	RE0300000K0	42	37
M90105810A0	58	42	NM6060001SC	4	48	RE0500000K0	2	17
M90115810A0	58	36	NM6060001SC	48	35	RE0500000K0	18	46
M90125800A0	52	15	NM6060001SC	48	65	RE0500000K0	26	26
M90125800A0	58	39	NM6080001SC	48	36	RE0500000K0	42	38
M90125810A0	54	11	NM6080721SE	44	12	RE0600000K0	34	27
M90125810A0	58	4	NM6080721SE	48	20	RE0600000K0	38	17
M9012581AA0	54	7	NM6120003SE	48	11	RE0700000K0	40	39
M9012581AA0	58	3				RE0900000K0	24	54
M90135810A0	58	33-34				RO092270200	2	26
M90145800A0	58	5				RO137230100	16	57

NUMERICAL INDEX OF PARTS

PART NO	PAGE	REF NO.	PART NO	PAGE	REF NO.	PART NO	PAGE	REF NO.
S9622710000	54	36	SL4041091SC	56	48	SM8040602TP	34	15
SB107000100	20	70	SL4041281SF	56	49	SM8050802TP	40	24
SB108000500	14	26	SL4042081SC	44	13	SM8050812TP	42	20
SB108000500	34	28	SL4051081SF	56	50	SM8060602TP	20	65
SB108000500	38	18	SL4051091SC	44	17	SM8060602TP	34	36
SB408000100	34	29	SL6052092TN	10	26	SM8060602TP	38	25
SB408000100	38	19	SL9061293SE	48	15	SM8060612TP	14	35
SB710000200	40	40	SL9082093SE	44	18	SM8060802TP	34	51
SB710000200	42	39	SL9082093SE	48	21	SM8060802TP	36	51
SB716000200	14	27	SM0040601SC	56	52	SM8060802TP	38	24
SD0400191TP	18	47	SM0051001SC	38	21	SM8060812TP	10	22
SD0500803TP	32	60	SM1040801SC	8	13	SM9065513SF	4	52
SD0530221SP	28	28	SM1040801SP	40	20	SM9086503SM	48	37
SD0600402TP	20	49	SM1040801SP	42	14	SS1060210TP	30	32
SD0640321SP	20	48	SM1044050SM	56	74	SS1060210TP	68	37
SD0640326TP	68	24	SM3065052TC	56	62	SS1110640TP	20	53
SD0640391TP	28	30	SM4030601SN	26	31	SS1110640TP	32	65
SD0640482SP	28	31	SM4031851SR	54	44	SS1110640TP	70	49
SD0650305TP	32	61	SM4050855SP	8	20	SS1110840SP	8	17
SD0650321TP	26	29	SM4051405SE	50	12	SS1110840SP	10	4
SD0720321TP	28	29	SM6040602TP	32	63	SS4090415SP	22	12
SD0720331SP	14	30	SM6040602TP	34	31	SS4090715SP	4	54
SD0790501SP	14	32	SM6040602TP	38	36	SS4110515SP	4	56
SD0790601SP	14	29	SM6040802TP	34	30	SS4110715SP	4	84
SD0800331TH	20	50	SM6041002TP	34	13	SS4110715SP	8	16
SD0800341SP	14	31	SM6041002TP	42	15	SS4110715SP	46	29
SD0800402TP	20	51	SM6041202TP	34	32	SS4110815SP	4	58
SD0800422CP	14	33	SM6041202TP	40	21	SS4110915SP	4	57
SD0801021TP	24	55	SM6041202TP	42	16	SS4111015SP	4	59
SD1100301TP	32	62	SM6041402TP	32	64	SS4111415SP	40	25
SK3311600SC	48	33	SM6041802TP	38	20	SS4111415SP	42	21
SK3382001SE	48	43	SM6051002TP	42	17	SS4120615SP	46	21
SK3382001SE	56	57	SM6051202TP	14	34	SS4120915SP	8	18
SK3451600SC	52	19	SM6053502TP	34	33	SS4120915SP	32	67
SK3512001SF	56	60	SM6060802TP	14	44	SS4121015SP	4	61
SL4030681SF	54	37-70	SM6061002TP	40	22	SS4150915SP	4	63
SL4030681SF	56	37-70	SM6061002TP	42	18	SS6060220SP	68	17
SL4030891SC	54	40	SM6061202TP	20	55	SS6060410TP	24	56
SL4031081SF	34	47	SM6061202TP	38	22	SS6090420SP	68	19
SL4040681SC	54	61	SM6061402TN	40	23	SS6090540SP	66	75
SL4040681SC	56	61	SM6061402TN	42	19	SS6090620SP	4	64
SL4040881SF	54	39	SM6061610SC	50	6	SS6090620TP	26	27
SL4040881SF	60	19	SM8040412TP	20	66	SS6090630TP	4	53
SL4041081SF	54	43	SM8040502TP	34	34	SS6090670TP	12	49
SL4041091SC	54	48	SM8040502TP	38	23	SS6092120SP	46	26

NUMERICAL INDEX OF PARTS

PART NO	PAGE	REF NO.	PART NO	PAGE	REF NO.	PART NO	PAGE	REF NO.
SS6110430TP	30	35	SS7110840SP	66	51	WP0450801SD	8	21
SS6110430TP	68	45	SS7110910SP	26	37	WP0450801SD	26	38
SS6110610TP	8	19	SS7111110TP	22	30	WP0450846SP	30	41
SS6110610TP	20	54	SS7111410SP	20	58	WP0450846SP	34	39
SS6110610TP	34	14	SS7111810TP	38	28	WP0450846SP	38	32
SS6111010SP	34	44	SS7151210SP	14	37	WP0450846SP	68	47
SS6111052TP	70	51	SS7151210SP	20	61	WP0480856SP	20	67
SS6111140SP	4	68	SS8090610SP	28	21	WP0480856SP	40	28
SS6111140SP	46	24	SS8110422TP	2	66	WP0480856SP	42	25
SS6111620SP	34	38	SS8110422TP	4	66	WP0480856SP	64	52
SS6120940SP	28	32	SS8110422TP	20	74	WP0480856SP	66	52
SS6121212TP	24	57	SS8110422TP	26	28	WP0482086SD	20	77
SS6121610SP	10	23	SS8110422TP	38	29	WP0482086SD	26	39
SS6121610SP	20	62	SS8110510SP	10	27	WP0482086SD	28	37
SS6151220SP	20	60	SS8110520TP	24	51	WP0501016SC	52	20
SS6151220SP	24	58	SS8111610SP	10	30	WP0501016SD	4	76
SS6151412TP	10	24	SS8120410SP	20	59	WP0501016SD	32	70
SS6151812TP	28	33	SS8120410SP	28	35	WP0520656SA	8	23
SS6681712TP	10	25	SS8120740SP	14	39	WP0520656SA	16	60
SS7060310SP	68	44	SS8150822TP	10	28	WP0531000SD	8	22
SS7080510TP	12	50	SS8150822TP	22	29	WP0531000SD	20	82
SS7090410SP	30	36	SS8150822TP	32	68	WP0531001SC	14	41
SS7090620TP	28	34	SS8151550SP	12	48	WP0531001SC	34	41
SS7090850SP	4	85	SS8660610TP	12	52	WP0551016SH	38	33
SS7090910SP	20	56	SS8660610TP	20	64	WP0611626SP	20	69
SS7090910SP	62	16	SS8661012TP	32	69	WP0621016SD	4	78
SS7091110SP	20	57	SS9110920CP	28	36	WP0621016SH	14	43
SS7091110SP	38	27	SS9120910TP	14	40	WP0621026SP	20	80
SS7091410SP	38	37	SS9150910SP	38	30	WP0641601SC	16	52
SS7110340SP	62	10	SS9661230CP	12	51	WP0641601SC	48	38
SS7110510SP	22	27	ST4031051SN	52	12	WP0651001SC	40	30
SS7110710SP	4	86	ST5041051SN	60	14	WP0651001SC	42	27
SS7110710SP	36	48	TA0750704R0	4	69	WP0651001SC	56	63
SS7110710SP	42	22	TA0850604R0	4	94	WP0651056SD	28	38
SS7110720SP	38	26	TA1050504R0	4	88	WP0740516SP	20	75
SS7110740TP	30	34	TA1250406R0	4	71	WP0820526SD	34	40
SS7110740TP	68	46	TA1850805R0	4	72	WP0841600SE	28	39
SS7110840SP	4	67	TA2100904R0	4	73	WP0850002SP	14	42
SS7110840SP	14	36	WP0320501SC	26	32	WP0851846SC	48	39
SS7110840SP	22	28	WP0430800SC	20	72	WP0871602SE	44	19
SS7110840SP	26	36	WP0430801SC	38	31	WP0871602SE	48	22
SS7110840SP	40	27	WP0450000SD	4	75	WP0952616SD	22	13
SS7110840SP	42	23	WP0450000SD	42	24	WP1702600S0	50	19
SS7110840SP	46	25	WP0450000SD	46	30	WP2232916SZ	16	53
SS7110840SP	64	51	WP0450801SD	6	95	WS0310002KR	26	22

NUMERICAL INDEX OF PARTS

PART NO	PAGE	REF NO.
WS0310702KS	54	45
WS0410002KP	38	38
WS0410002KP	40	32
WS0410002KP	42	29
WS0510002KN	50	16
WS0610002KN	48	40
WS0610002KN	56	64
WZ0430200KH	64	53
WZ0430200KH	66	53